

Elektror

airsystems gmbh

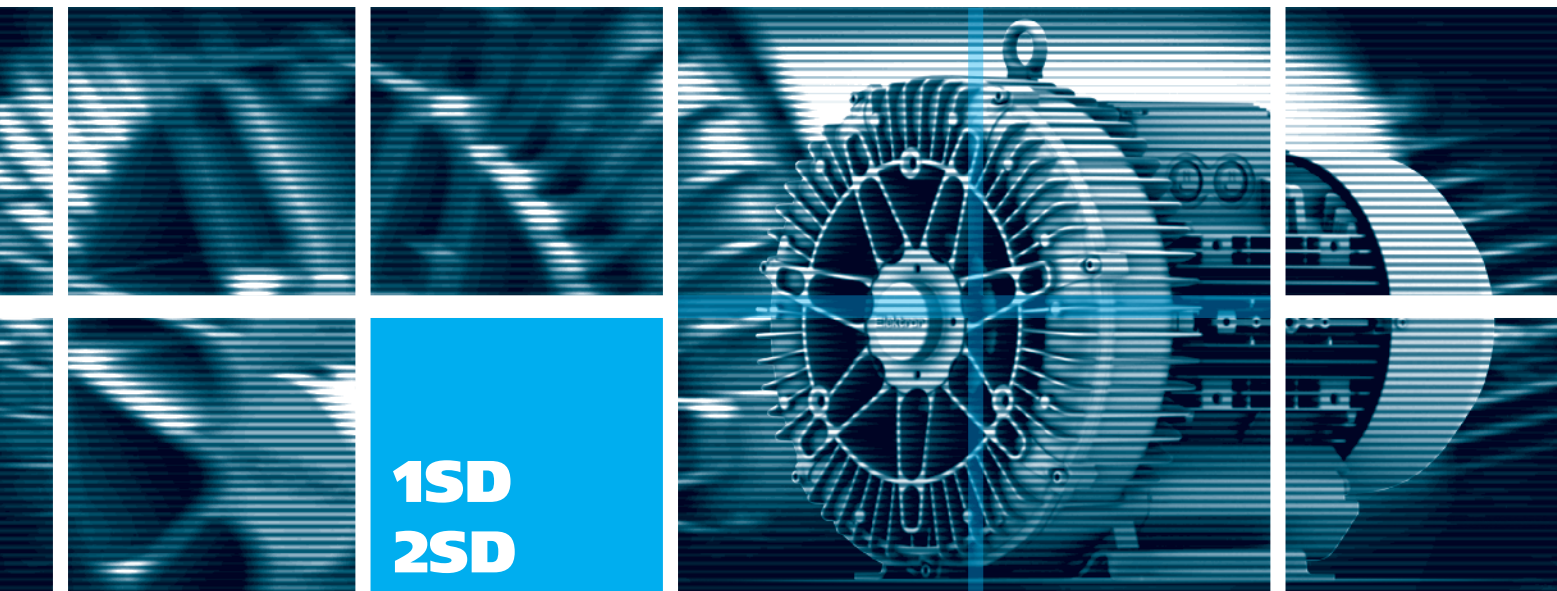

1SD
2SD

Seitenkanal-
verdichter
*Side channel
blowers*





INHALTSVERZEICHNIS TABLE OF CONTENTS

Elektror Seitenkanalverdichter bieten vielfältige Anwendungsmöglichkeiten und werden überall dort eingesetzt, wo Luft als Energieträger zu optimalen Lösungen führt. Die aufgeführten Einsatzgebiete können deshalb nur einen kleinen Überblick über die breite Anwendungspalette dieser Geräte darstellen.

Elektror side channel blowers offer a wide field of application facilities wherever the use of air as energy supply leads to optimum results. The fields of application listed below present just a small summary therefore of the wide range of possible use of these units.

- Rohrpostanlagen
- Pneumatische Förderanlagen
- Staubsauger
- Vakuumheber
- Vakuum-Transportanlagen
- Flaschen-Abfüllanlagen
- Druckmaschinen
- Siebdruckmaschinen
- Lufttische
- Trocknungsanlagen
- Schweißgasabsaugung
- Textilmaschinen
- Landmaschinen
- Dentalanlagen
- Wasseraufbereitung
- Fischteichbelüftung
- Aquarienbelüftung
- Belüftung galvanischer Bäder
- Pneumatic air tube systems
- Pneumatic conveying systems
- Vacuum cleaning systems
- Vacuum lifting gear
- Vacuum transport systems
- Bottle-filling stations
- Printing machines
- Screen printing machines
- Air-cushion tables
- Drying systems
- Welding fume extraction
- Textile machinery
- Agricultural machines
- Dental equipment
- Water treatment
- Fish pond aeration
- Aquarium aeration
- Aeration of galvanic tanks

1. Technische Hinweise/Technical information	Seite/page 3
1.1 Funktion/Function	Seite/page 3
1.2 Aufbau/Design	Seite/page 3
1.3 Zubehör/Accessories	Seite/page 4
1.4 Betriebshinweise/Operating performance	Seite/page 4
1.5 Drehzahlgesteuerte Seitenkanalverdichter/Variable-speed side channel blowers	Seite/page 5
1.6 Reversierautomaten/Reversing units	Seite/page 5
1.7 Bestellangaben/Details for ordering	Seite/page 6
1.8 Anmerkungen/Remarks	Seite/page 6
1.9 Umrechnungstabelle/Conversion table	Seite/page 7
2. Typenschlüssel/Type code	Seite/page 8
3. Vorauswahl, Kennlinien/Preselection, characteristic curves	Seite/page 8
4. Einstufige Seitenkanalverdichter: Kennlinien mit Maßbildern und technischen Daten Single stage side channel blowers: Characteristic curves with dimensional drawings and technical data	Seite/page 10
5. Zweistufige Seitenkanalverdichter: Kennlinien mit Maßbildern und technischen Daten Double stage side channel blowers: Characteristic curves with dimensional drawings and technical data	Seite/page 25
6. Doppelflutige Seitenkanalverdichter: Kennlinien mit Maßbildern und technischen Daten Double flow side channel blowers: Characteristic curves with dimensional drawings and technical data	Seite/page 37
7. Frequenzumrichter/Frequency converter	Seite/page 40
8. Reversierautomaten/Reversing units	Seite/page 43
9. Zubehör/Accessories	Seite/page 44
9.1 Anschluss-Systemkomponenten/System components for mechanical connection	Seite/page 54

SEITENKANALVERDICHTER SIDE CHANNEL BLOWERS



Elektror Seitenkanalverdichter sind:

- Berührungsfrei laufende Druck- und Vakuumerzeuger
- Geräuschgedämpft
- Wartungsfrei
- Kompakt
- Absolut ölfrei

Elektror side channel blowers offer:

- **Non-contact operating pressure and vacuum generators**
- **Low noise level**
- **Maintenance-free**
- **Compact design**
- **Completely oil-free**

1. Technische Hinweise/Technical information

1.1 Funktion

Laufrad und Seitenkanal bilden gegenüberliegend angeordnet einen ringförmigen Arbeitsraum, der zwischen Ansaug- und Ausblasstutzen unterbrochen ist. Bei Drehung des Laufrades erfolgt ein radialer Druckaufbau in den Schaufelzellen, welcher eine unterschiedliche Druckverteilung zwischen Kanal und Laufrad bewirkt, so dass eine Umlaufströmung zwischen Kanal und Schaufelzellen entsteht. Durch den Schaufeldruck erfolgt in Drehrichtung eine weitere Beschleunigung, so dass sich ein schraubenförmiger Durchsatz durch den Verdichter einstellt und einen hohen Druckaufbau bewirkt.

1.2 Aufbau

Seitenkanalverdichter von Elektror werden mit Kurzschlussläufermotoren direkt angetrieben.

Seitenkanalverdichter von Elektror sind mit Rillenkugellager ausgerüstet, diese müssen nicht nachgeschmiert werden und haben eine Mindestlebensdauer von 22.000 Stunden. Die Lebensdauer der Kugellager ist abhängig von den Betriebsstunden und sonstigen Einflüssen wie Temperatur usw. Ein Austausch der Rillenkugellager vor Ablauf der Lebensdauer wird empfohlen.

Serienmäßig angebaute Schalldämpfer auf der Druck- und Ansaugseite sorgen für eine geringst mögliche Geräuschentwicklung. Sämtliche Verdichter- und Motorenteile sind aus Aluminiumguss gefertigt und dadurch weitgehend korrosionsbeständig.

Verrippungen an Verdichtergehäuse und Deckel erbringen eine gute Wärmeableitung, die durch den Motorluftstrom noch unterstützt wird. Alle Verdichter sind serienmäßig mit Fuß ausgestattet, so dass ein Anbau in horizontaler oder vertikaler Lage möglich ist.

1.1 Function

Impeller and side channel facing each other form a circular working chamber which is intersected between intake and discharge port. The rotation of the impeller causes a radial pressure rise in the cellular-shaped vanes which leads to a differing pressure distribution between channel and impeller resulting in a rotational flow between channel and cellular vanes. The pressure generated by the vanes ensues a further acceleration in the direction of rotation leading to a helical flow motion through the blower and a high pressure increase.

1.2 Design

Side channel blowers made by Elektror are directly driven by asynchronous squirrel cage motors of the company's own make.

Side channel blowers from Elektror are fitted with deep groove ball bearings with a minimum service life of 22.000 hours. They do not have to be lubricated. The service life of the ball bearings depends on the operating hours, the strain and other influences such as temperature etc. A change of the deep groove ball bearings before the ending of the service life is recommended.

Amplly dimensioned sealed bearings ensure maintenance-free operation. As standard equipment silencers are mounted on the discharge and intake side thereby reducing the noise level considerably. All blowers and motor parts are made of cast aluminium and therefore highly resistant to corrosion.

The ribs on the blower housing provide for a good heat dissipation, further assisted by the air flow of the motor fan. All blowers are equipped generally with a base plate on the silencer for mounting in a vertical or horizontal position.



TECHNISCHE HINWEISE TECHNICAL INFORMATION

1.3 Zubehör

Vielseitiges Zubehör erlaubt einen sinnvollen, zweckmäßigen Einbau von Elektror-Seitenkanalverdichtern.

1.4 Betriebshinweise

Seitenkanalverdichter von Elektror können über den gesamten Bereich der angegebenen Kennlinien eingesetzt werden und arbeiten pulsationsfrei. Sie sind zur Förderung von Luft sowie zur Druck- und Vakuumerzeugung geeignet. Der Einsatz von Geräten für aggressive und giftige Medien, für Luft mit extrem hohem Feuchtigkeitsgehalt sowie Fördermitteltemperaturen über +40 °C und unter -20 °C kann nur nach genauer Abklärung erfolgen. Die Förderung explosionsfähiger Gemische ist nicht zulässig. Die Geräte sind witterungsgeschützt aufzustellen und dürfen auch im anschließenden Betrieb keinen Schwing- und Stoßbelastungen, sowie Erschütterungen ausgesetzt werden. Geräte über 3,0 kW sind Y/Δ einzuschalten.

Enthält das zu fördernde Medium Feststoffe oder andere Verunreinigungen, so sind diese vor Eintritt in den Verdichter durch saugseitig angebaute Filter etc. abzuscheiden. Offene Ansaug- oder Ausblasstutzen sind mit entsprechenden Schutzgittern nach DIN EN ISO 13857 zu versehen.

Bei Verdichtern, deren Kennlinie im hohen Druckbereich begrenzt ist, sollten je nach Einsatz die dafür bestimmten Druckbegrenzungsventile vorgesehen werden, um eine Überlastung zu vermeiden. Sie werden bei druckseitiger Drosselung direkt auf der Druckseite des Verdichters aufgebaut, bei saugseitiger Drosselung auf der Saugseite des Verdichters. Die Einstellung auf den zulässigen max. Druck des Verdichters erfolgt werksseitig.

Die in den Kennlinien angegebenen Luftwerte gelten mit einer Toleranz von ±10 % für den Zustand im Saugstutzen bei 20 °C und einem Gegendruck von 1 bar (abs.).

1 mbar = 100 Pa = 100 N/m²

Der jeweils angegebene Schalldruckpegel wurde in 1 m Abstand vom Gerät bei druckseitiger Drosselung und saugseitig angeschlossener Schlauchleitung gemessen.

Die Antriebsmotoren entsprechen der EN 60034-1 (VDE 0530 Teil 1) und sind in Schutzart IP 55 sowie der Wärmeklasse F ausgeführt. Die Motoren sind für Dauerbetrieb geeignet.

1.3 Accessories

A variety of accessories allow for a convenient installation of the Elektror side channel blowers.

1.4 Operating performance

Side channel blowers from Elektror may be operated – pulsation-free – over the whole range of their performance curves. They are designed for the conveying of air as well as for generating pressure or vacuum. The use of the units for aggressive and toxic media, air of high humidity and medium temperatures exceeding +40 °C and below -20 °C is subject to a detailed clarification. The conveying of explosive gases is not permitted. The units are to be installed in weather-protected places and must not be exposed to strain by vibrations, shocks and percussions. Units above 3,0 kW must be started in Y/Δ configuration.

If the medium to be conveyed contains solid particles or other pollutions, they are to be removed before entering the blower by installing a filter – or similar device – on the intake side. Open intake or discharge ports should be fitted with corresponding wire mesh guards in accordance with DIN EN ISO 13857.

Blowers with limited performance curves in the high pressure range should be fitted – depending on the application – with the relative pressure relief valves in order to avoid an overload of the motor. Pressure relief valves can be mounted directly on the discharge port, vacuum relief valves directly on the intake port of the blower. Adjustment of the permitted maximum pressure of the blower is made in the factory.

The rated values indicated in the performance curves are valid within a tolerance of ±10% and are related to inlet conditions at 20 °C and back pressure of 1 bar (abs.).

1 mbar = 100 Pa = 100 N/m²

The sound pressure level has been ascertained at a distance of 1 m from the blower unit with reduction of the discharge port and an air duct connected to the intake side.

The drive motors are manufactured in accordance with EN 60034-1 (VDE 0530 Part 1), amply dimensioned and suited for continuous operation. As a standard the motor insulation is class F and enclosure IP 55. The motors are suitable for continuous operation.



Zulässige Umgebungstemperaturen		Admissible ambient temperature	
-20 °C bis +40 °C	<ul style="list-style-type: none"> - Standardgeräte mit einer Bemessungsspannung (max. $\pm 10\%$ Spannungstoleranz) und einer Bemessungsfrequenz von 50 Hz oder 60 Hz - FU-/FUK-Reihe - UL-Approval 	-20 °C to +40 °C	<ul style="list-style-type: none"> - Standard motors with a rated voltage (max. $\pm 10\%$ voltage tolerance) and a rated frequency of 50 Hz or 60 Hz - FU/FUK series - UL approval

Detaillierte Hinweise über Aufstellung und Betrieb von Seitenkanalverdichtern sind der Montage- und Betriebsanleitung zu entnehmen.

Details about installation and operation of side channel blowers may be obtained from the installation and operation instruction.

1.5 Drehzahlgesteuerte Seitenkanalverdichter

Sie werden überall dort eingesetzt, wo aus prozessluft- oder verfahrenstechnischen Gründen veränderte Volumenströme oder Drücke benötigt werden oder diese Leistungsparameter konstant gehalten werden müssen.

Vorteile:

- Energie- und Kostenersparnis durch optimierte Anwendungen
- Geräte werden schonender betrieben, dadurch Verlängerung der Lebensdauer
- keine unnötige Geräuschbelastung und Wärmeentwicklung

Alle Seitenkanalverdichter mit 3~ Antriebsmotor sind geeignet für Frequenzumrichterbetrieb (drehzahlsteuerbar). Die Geräte sind serienmäßig mit Temperaturwächter (Öffnerkontakt) ausgestattet. Der Drehzahlstellbereich darf bei der 50 Hz-Ausführung 50 Hz, bei der 60 Hz-Ausführung 60 Hz nicht überschreiten. Die technische Daten sind identisch mit den Serienausführungen.

Unsere Frequenzumrichter sind in der Standardausführung für die EMV-Grenzwertklasse B lieferbar (übertrifft die Grenzwerte für Industrieanwendung).

Weitere Informationen zu Frequenzumrichter-geeigneten Geräten erhalten Sie von unserem [Produktmanagement](#).

1.6 Reversierautomaten

Elektror-Reversierautomaten sind elektromotorisch betriebene Umsteuerventile für Seitenkanalverdichter und werden direkt auf diese aufgebaut. Sie ermöglichen es, Rohrleitungen, Anlagen oder Systeme innerhalb kürzester Zeit wechselweise mit Überdruck oder Vakuum zu beaufschlagen oder drucklos zu machen, ohne dass der jeweilige Verdichter in seiner Drehrichtung geändert bzw. abgeschaltet werden muss.

Der Steuerkolben arbeitet berührungslos und wird von

1.5 Variable-speed side channel blowers

These are used anywhere where changed volumetric flows or pressures are required for process control or process engineering reasons or these output parameters have to be kept constant.

Advantages:

- Energy and cost saving through optimized application
- Devices are operated with less stress, resulting in an extended life
- No unnecessary noise load and generation of heat

All side channel blowers with 3~ drive motor are suitable for frequency converter operation (speed controllable). The devices are equipped with a temperature guard (break contact) as a standard. The range of speed control must not exceed 50 Hz with the 50 Hz version or 60 Hz with the 60 Hz version. The technical specifications are identical to those of the series versions.

Our frequency converter can be supplied in the standard version for EMC limit class B (exceeds the limits for industrial applications).

Further information on devices suitable for frequency inverters is available from our [Product Management](#).

1.6 Reversing units

Elektror reversing units are motor driven reversing valves for side channel blowers and are mounted directly onto them. They allow for generating alternate pressure or vacuum in pipes, installations or systems within the short-est possible time, or to reduce pressure or vacuum to zero, without having to change the direction of rotation of the blower nor switching it off.

The non-contact actuating piston is driven by a reversible synchronous gear motor which is set into the required posi-



TECHNISCHE HINWEISE TECHNICAL INFORMATION

einem blockierfesten, reversierbaren Synchronmotor mit Getriebe angetrieben, der durch Umpolung in die jeweilige Position geschaltet wird. Sämtliche Reversierautomaten sind aus Aluminiumguss gefertigt und somit weitgehend korrosionsbeständig. Die Lagerung des Steuerkolbens erfolgt mittels einseitig geschlossener Rillenkugellager.

Anschlussflansche am Verbraucheranschluss sowie am Zu- und Abluftanschluss gewährleisten eine problemlose Installation und die Möglichkeit, sämtliche Zubehörteile wie Feinfilter, Schalldämpfer, Druckbegrenzungsventile etc. anzubauen.

tion by pole reversal: All reversing valves are cast aluminium and therefore highly resistant to corrosion. One-sided sealed, deep groove ball bearings are used for the bedding of the actuating piston.

Connecting flanges to the consumer system as well as discharge and intake connectors ensure problem-free installation and the possibility to attach all accessories such as fine filters, silencers, relief pressure valves etc.

RAGZ

Umschaltung von Druck- auf Saugbetrieb mit neutraler Zwischenstellung (System drucklos) oder umgekehrt. In neutraler Zwischenstellung ist der Verbraucheranschluss geschlossen.

Switch-over from pressure or vacuum operation with RAGZ..11 neutral intermediate position (pressure or vacuum to system is cut off) or vice versa. In the neutral position the consumer port is closed down.



Verdichter
Blower



Verdichter
Blower



Verdichter
Blower

1.7 Bestellangaben

- Verdichtertyp
- Volumenstrom
- Benötigte Gesamtdruckdifferenz
- Spannung
- Frequenz
- Umgebungstemperatur
- Fördermitteltemperatur
- Fördermitteldichte
- Art des Fördermediums
- Anwendungsgebiet
- Zubehör/Sonderwünsche

1.8 Anmerkung

Maßangaben, technische Daten und Beschreibungen sind nur annähernd maßgebend. Änderungen und evtl. Irrtum vorbehalten.

1.7 Details for ordering

- Blower type
- Volumetric flow rate
- Required total pressure difference
- Voltage
- Frequency
- Ambient temperature
- Temperature of the conveyed medium
- Density of conveyed medium
- Conveyed medium
- Field of application
- Accessories/special requirements

1.8 Remarks

Dimensions, technical data and descriptions are approximate only. Subject to modifications and errors.

TECHNISCHE HINWEISE TECHNICAL INFORMATION



1.9 Umrechnungstabelle/Conversion table

Maßeinheiten/units of measurement

	von Maßeinheit <i>by unit of measurement</i>	mit Umrechnungsfaktor <i>with conversion factor</i>	in Maßeinheit <i>in units of measurement</i>	von Maßeinheit <i>by units of measurement</i>	mit Umrechnungsfaktor <i>with conversion factor</i>	in Maßeinheit <i>in units of measurement</i>
Druck/Pressure	bar	1000	mbar	mbar	0,001	bar
Druck/Pressure	mbar	100	Pa	Pa	0,01	mbar
Druck/Pressure	mmWS	0,098	mbar	mbar	10,2	mm H ₂ O
Druck/Pressure	mWS	98,07	mbar	mbar	0,0102	m H ₂ O

Europäische Maßeinheiten in USA Maßeinheiten/European units of measurement in the USA

	von SI-Maßeinheit <i>by SI unit of measurement</i>	mit Umrechnungsfaktor <i>with conversion factor</i>	in anglo-amer. Maßeinheit <i>in anglo-amer. unit of measur.</i>	von anglo-amer. Maßeinheit <i>by anglo-amer. unit of measur.</i>	mit Umrechnungsfaktor <i>with conversion factor</i>	in SI-Maßeinheit <i>in SI unit of measurement</i>
Druck/Pressure	mbar	0,014	psi = lb/in ²	psi = lb/in ²	68,95	mbar
Druck/Pressure	bar	14,5	psi = lb/in ²	psi = lb/in ²	0,068	bar
Druck/Pressure	mbar	0,402	inches water	inches water	2,49	mbar
Volumenstrom/ Volumetric flow rate	m ³ /min	264,2	gal/min	gal/min	0,003	m ³ /min
Volumenstrom/ Volumetric flow rate	m ³ /min	35,31	cfm	cfm	0,028	m ³ /min
Elektrische Leistung/ Electric power	kW	1,36	hp	hp	0,735	kW
Länge/Length	mm	0,039	inch	inch	25,4	mm
Länge/Length	m	39,37	inch	inch	0,025	m
Länge/Length	mm	0,003	ft	ft	305	mm
Länge/Length	m	3,28	ft	ft	0,305	m
Gewicht/Weight	kg	2,05	lb	lb	0,454	kg

Beispiel für Umrechnung/Example for conversion

Druck/Pressure	180 mbar	0,014	2,61 PSI	2,61 PSI	68,95	180 mbar
Volumenstrom/ Volumetric flow rate	6 m ³ /min	35,31	211,8 ft ³ /min	211,8 ft ³ /min	0,283	6 m ³ /min



TECHNISCHE HINWEISE 1SD/2SD TECHNICAL INFORMATION 1SD/2SD

2. Typenschlüssel/Type code

Ein-, doppelstufige und doppelflutige Seitenkanalverdichter /
Single stage, double stage and double flow side channel blowers

1SD / 2SD 210 - 50 / 0,37

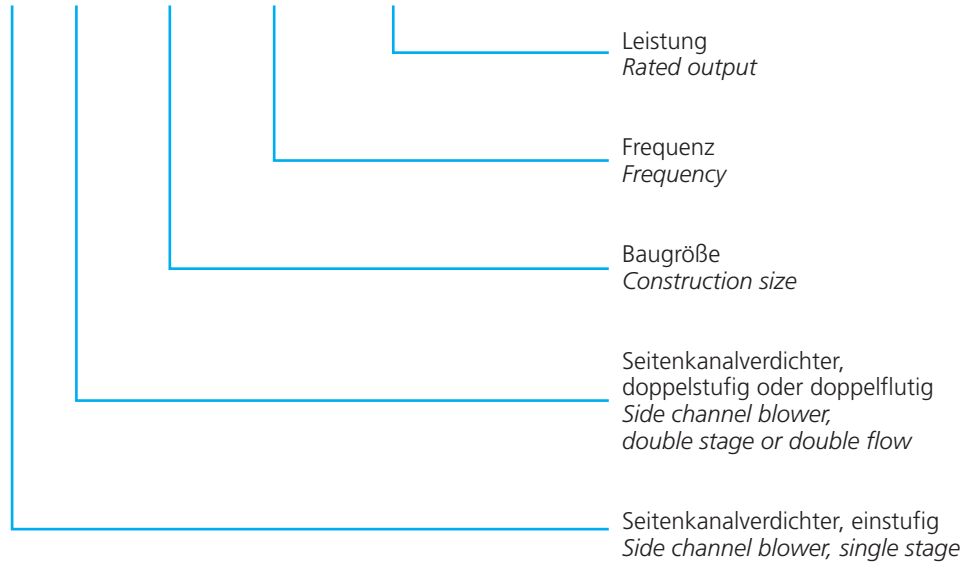

3. Vorauswahl, Kennlinien/Preselection, characteristic curve

Einstufige Seitenkanalverdichter
Single stage side channel blowers

Seite 10-24
Page 10-24

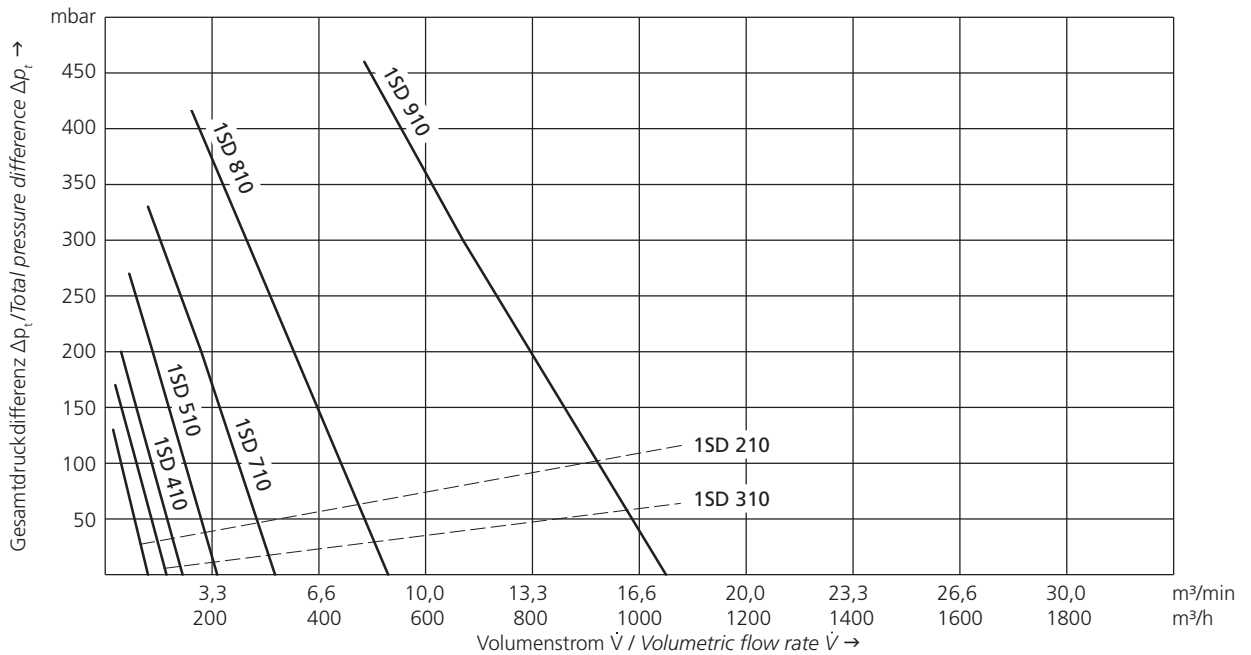

TECHNISCHE HINWEISE 1SD/2SD
TECHNICAL INFORMATION 1SD/2SD



Doppelstufige Seitenkanalverdichter
Double stage side channel blowers

Seite 25-36
Page 25-36

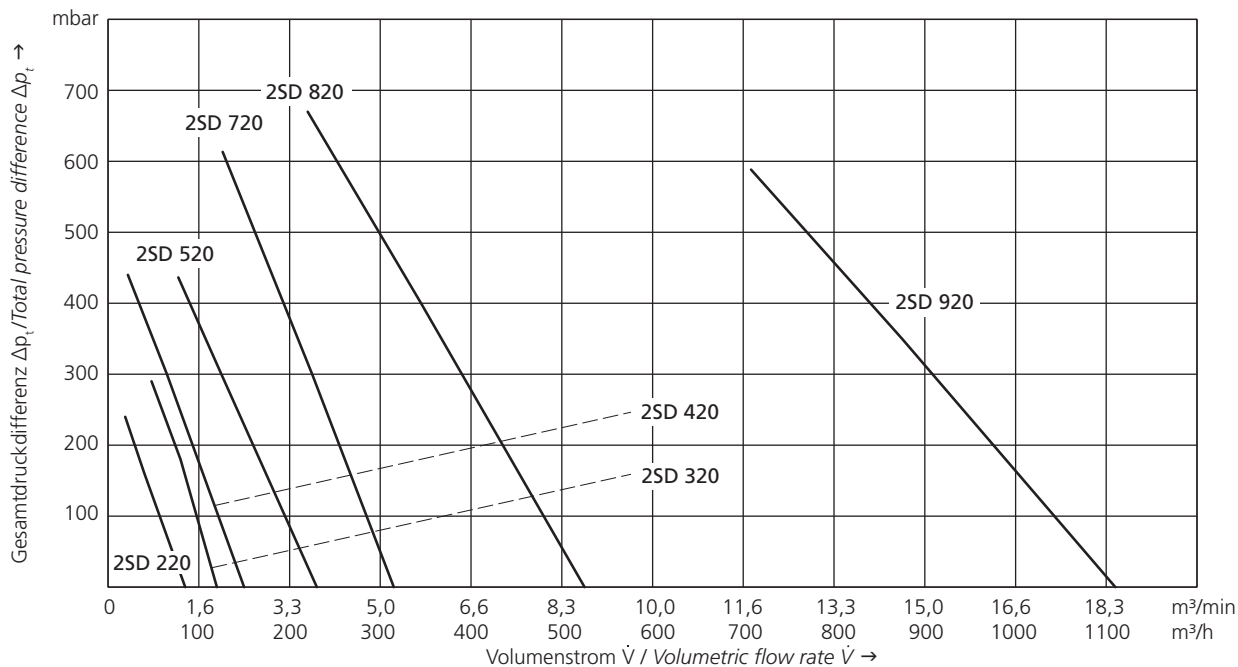

Doppelflutige Seitenkanalverdichter Seite 37-39
Double flow side channel blowers Page 37-39

FU/FUK-Geräte
FU/FUK devices

Seite 17
Page 17

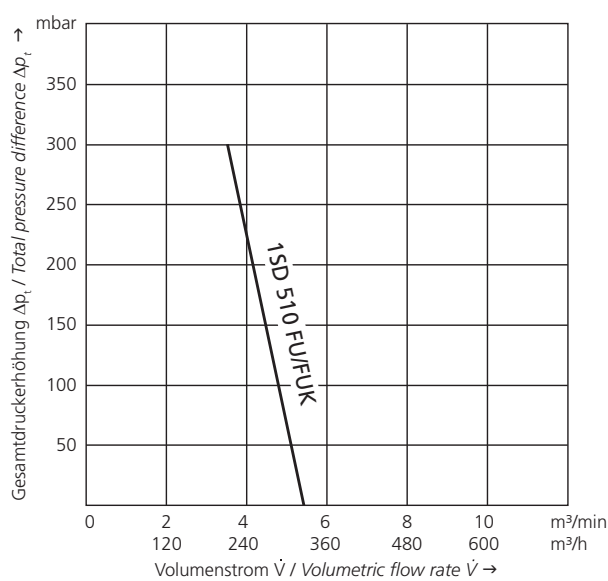
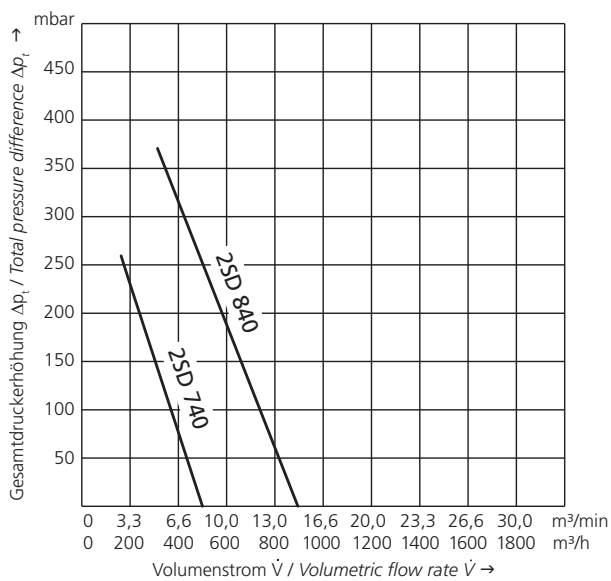

1SD 210

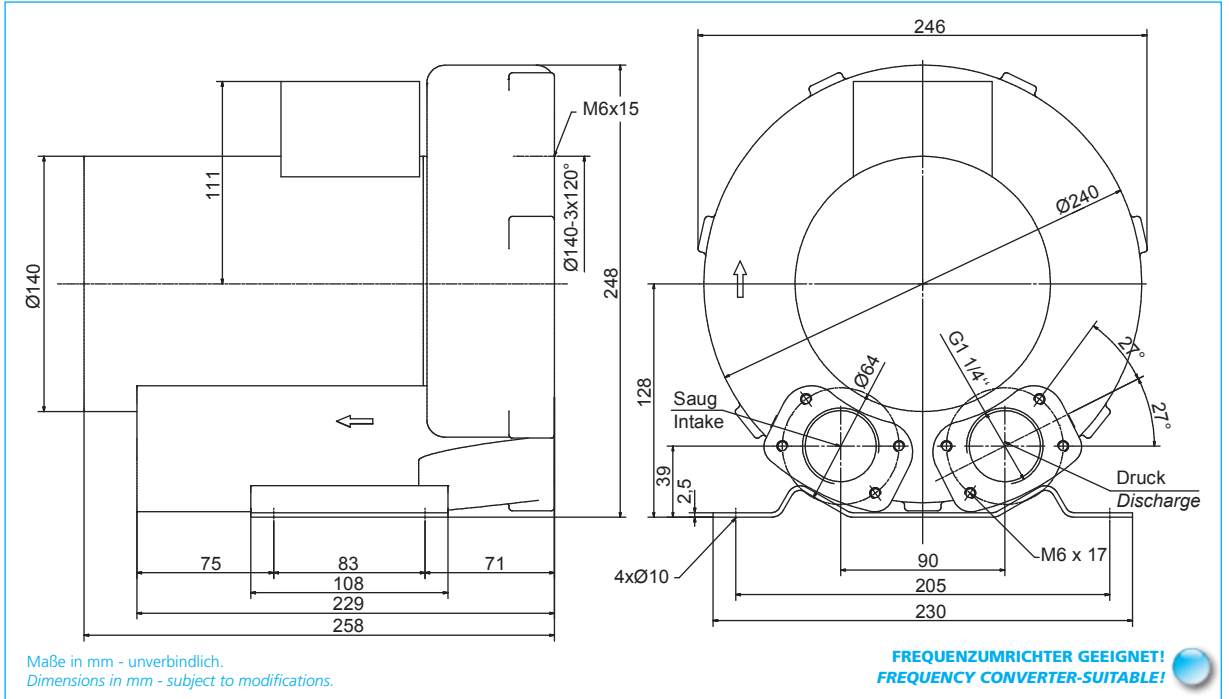

Typ Type	Frequenz Frequency	Grenzwerte der Drosselkurve Überdruck Maximum performance when used as blower		Grenzwerte der Drosselkurve Unterdruck Maximum performance when used as extractor		Nennwerte des Motors Motor ratings			Schalldruckpegel Sound pressure level	Gewicht (ca.) Weight (approx.)
		\dot{V} max. \dot{V} max.	Δp_t max. Δp_t max.	\dot{V} max. \dot{V} max.	Δp_t max. Δp_t max.	Leistung Rated output	Spannung Voltage	Strom Current		
	Hz	m ³ /min	mbar	m ³ /min	mbar	kW	V	A	dB (A)	kg
1SD 210 ✓	50	1,33	130	1,33	120	0,37	207-253/ 360-440	1,80/1,04	53	10
	60	1,63	160	1,63	150	0,63	220-250/ 415-480	2,40/1,40	56	10

Überdruck / Pressure

Unterdruck / Vacuum

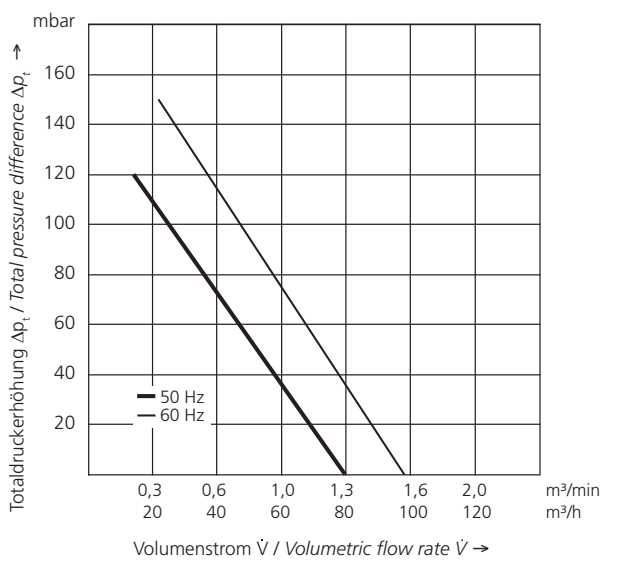
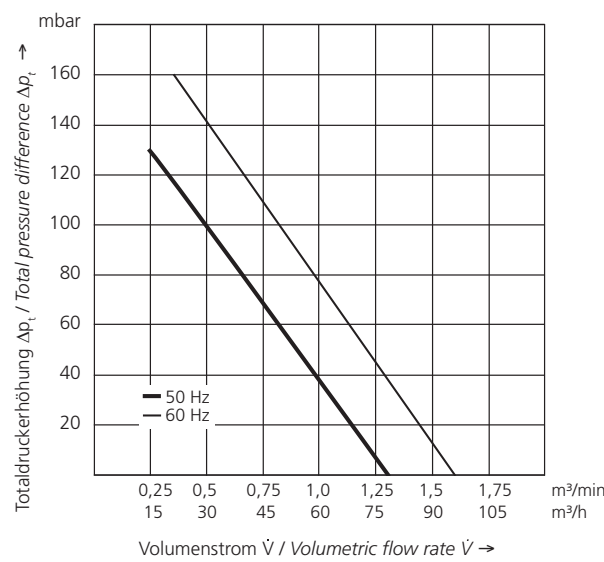

1SE 210

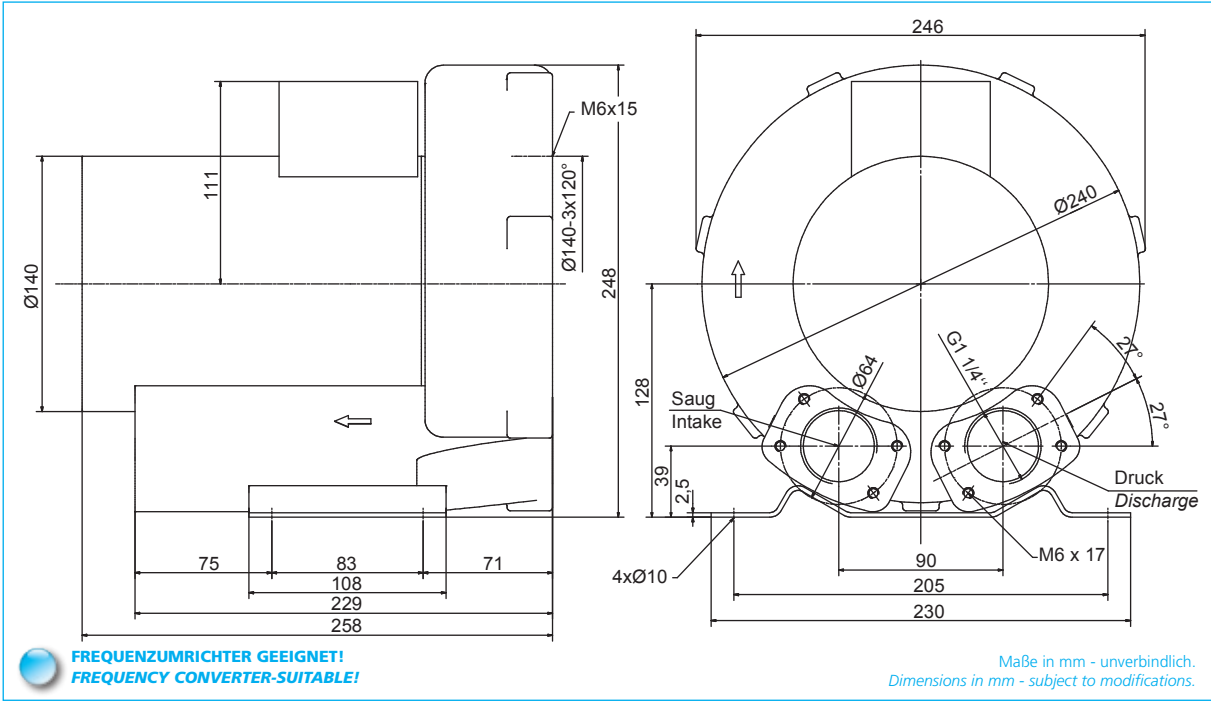

FREQUENZUMRICHTER GEEIGNET!
FREQUENCY CONVERTER-SUITABLE!

Maße in mm - unverbindlich.
Dimensions in mm - subject to modifications.

Typ Type	Frequenz Frequency	Grenzwerte der Drosselkurve Überdruck Maximum performance when used as blower		Grenzwerte der Drosselkurve Unterdruck Maximum performance when used as extractor		Nennwerte des Motors Motor ratings			Schalldruckpegel Sound pressure level	Gewicht (ca.) Weight (approx.)
		\dot{V}_{max} \dot{V}_{max}	Δp_t max. Δp_t max.	\dot{V}_{max} \dot{V}_{max}	Δp_t max. Δp_t max.	Leistung Rated output	Spannung Voltage	Strom Current		
	Hz	m ³ /min	mbar	m ³ /min	mbar	kW	V	A	dB (A)	kg
1SE 210	50	1,33	130	1,33	120	0,37	230	2,70	53	10
	60	1,63	160	1,63	150	0,43	230	3,20	56	10

Überdruck / Pressure

Unterdruck / Vacuum

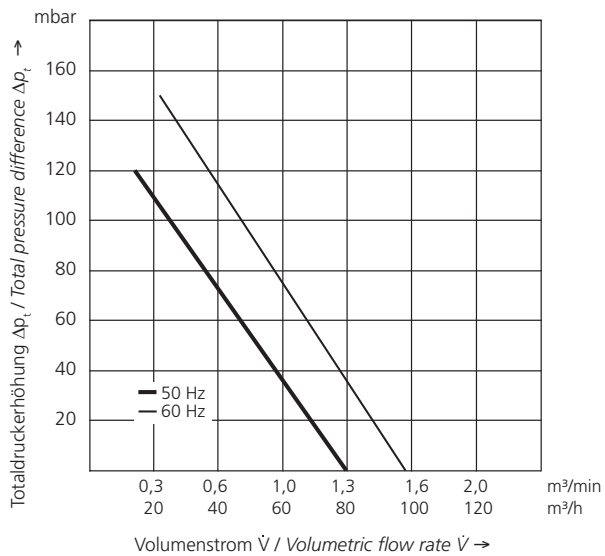
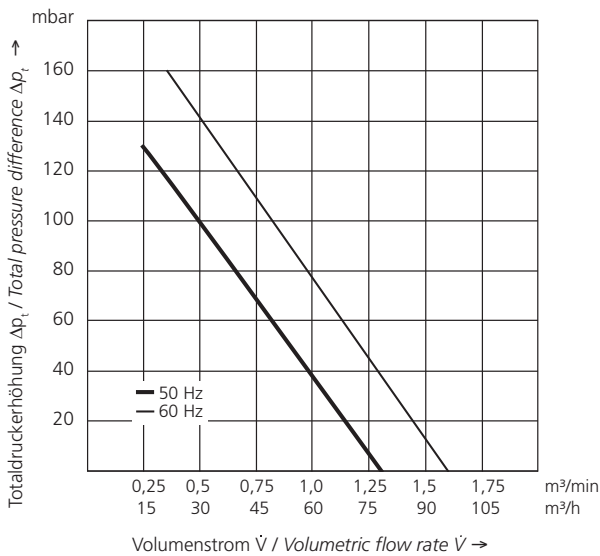

1SD 310

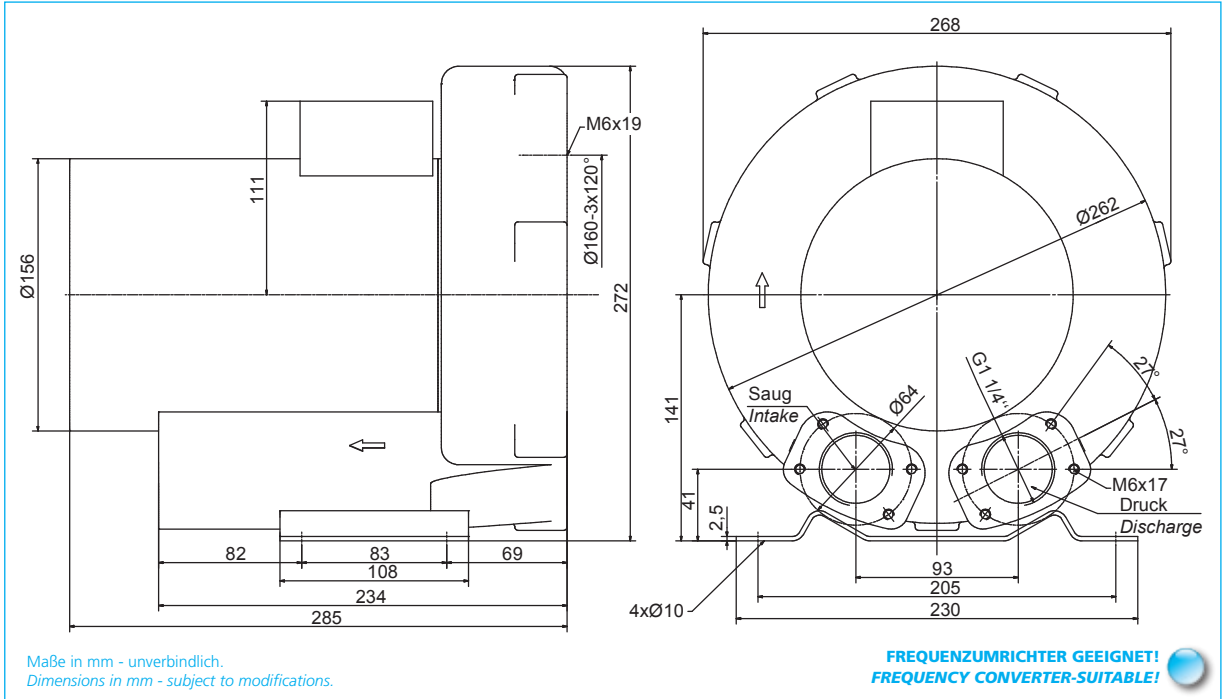

Typ Type	Frequenz Frequency	Grenzwerte der Drosselkurve Überdruck Maximum performance when used as blower		Grenzwerte der Drosselkurve Unterdruck Maximum performance when used as extractor		Nennwerte des Motors Motor ratings			Schalldruckpegel Sound pressure level	Gewicht (ca.) Weight (approx.)
		\dot{V} max. \dot{V} max.	Δp_t max. Δp_t max.	\dot{V} max. \dot{V} max.	Δp_t max. Δp_t max.	Leistung Rated output	Spannung Voltage	Strom Current		
	Hz	m ³ /min	mbar	m ³ /min	mbar	kW	V	A	dB (A)	kg
1SD 310 ✓	50	1,92	150	1,92	150	0,75	207-253/ 360-440	2,95/1,70	55	13
	60	2,33	140	2,33	150	1,30	220-250/ 415-480	4,8/2,80	57	13
1SD 310 ✓	50	1,92	170	1,92	150	1,10	207-253/ 360-440	4,35/2,50	55	13
	60	2,33	180	2,33	180	1,50	220-250/ 415-480	5,0/2,90	57	13

Überdruck / Pressure **Unterdruck / Vacuum**

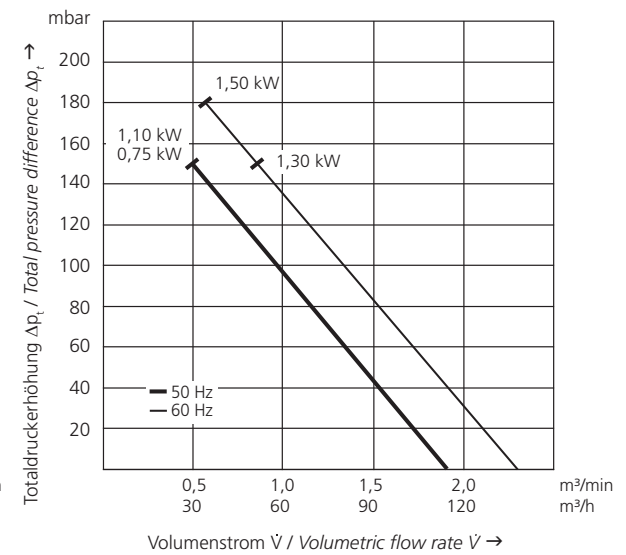
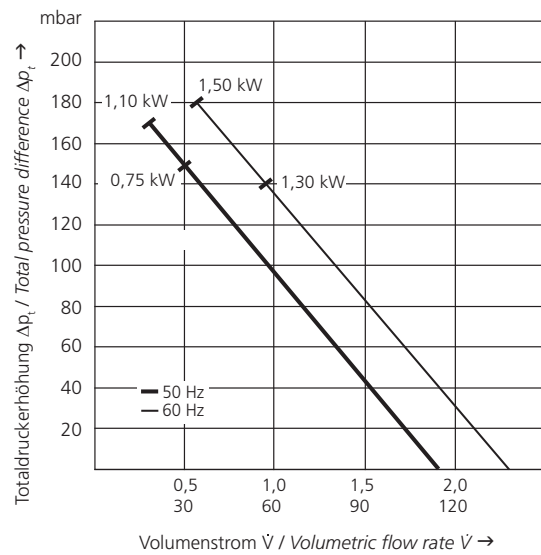

1SD 410

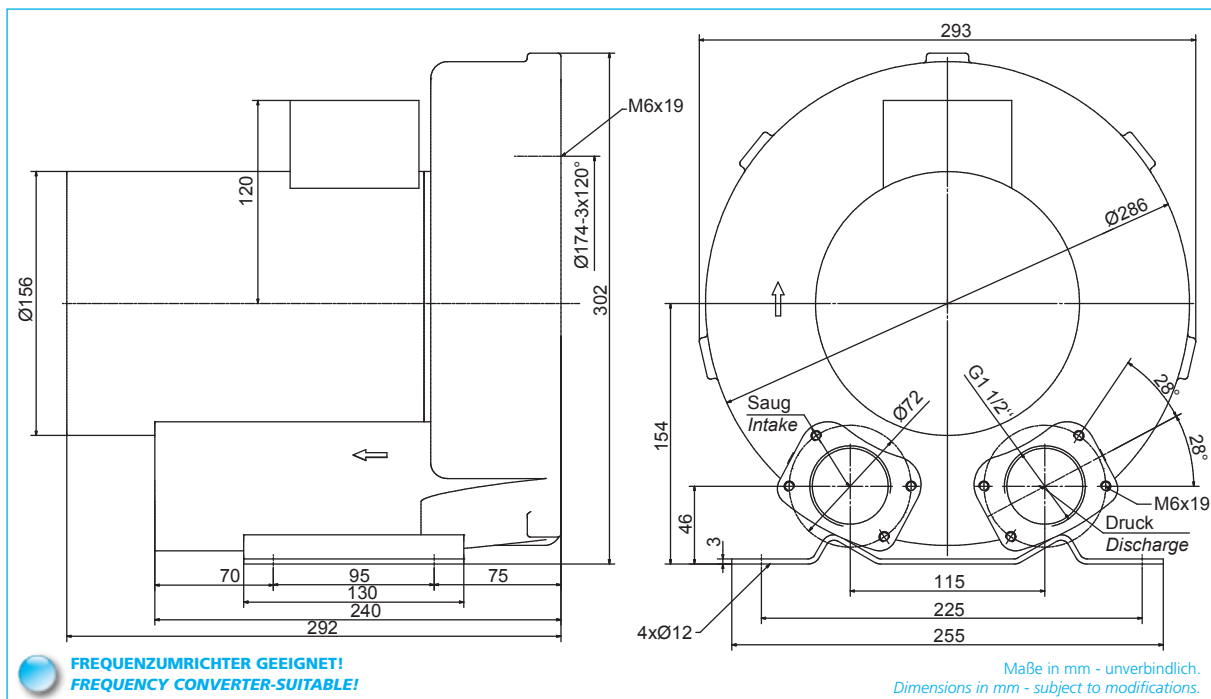

FREQUENZUMRICHTER GEEIGNET!
FREQUENCY CONVERTER-SUITABLE!

Maße in mm - unverbindlich.
Dimensions in mm - subject to modifications.

Typ Type	Frequenz Frequency	Grenzwerte der Drosselkurve Überdruck Maximum performance when used as blower		Grenzwerte der Drosselkurve Unterdruck Maximum performance when used as extractor		Nennwerte des Motors Motor ratings			Schalldruckpegel Sound pressure level	Gewicht (ca.) Weight (approx.)
		\dot{V} max. \dot{V} max.	Δp_t max. Δp_t max.	\dot{V} max. \dot{V} max.	Δp_t max. Δp_t max.	Leistung Rated output	Spannung Voltage	Strom Current		
	Hz	m ³ /min	mbar	m ³ /min	mbar	kW	V	A	dB (A)	kg
1SD 410 ✓	50	2,42	160	2,42	160	0,75	207-253/ 360-440	2,95/1,70	63	16
	60	2,92	160	2,92	160	1,30	220-250/ 415-480	4,8/2,80	64	16
1SD 410 ✓	50	2,42	200	2,42	170	1,10	207-253/ 360-440	4,35/2,50	63	16
	60	2,92	220	2,92	210	1,50	220-250/ 415-480	5,0/2,90	64	16

Überdruck / Pressure

Unterdruck / Vacuum

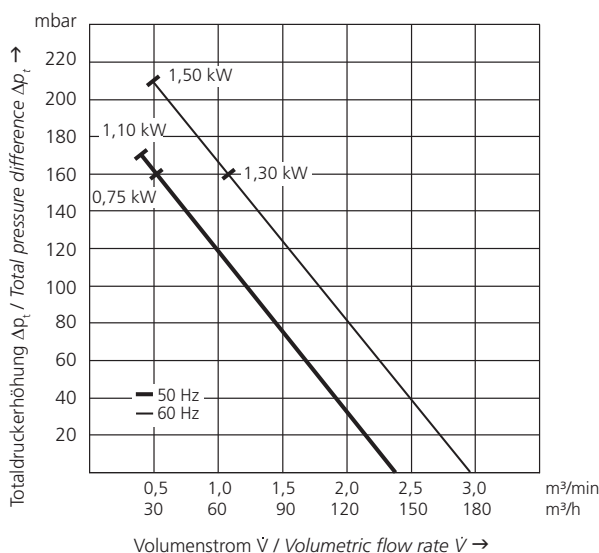
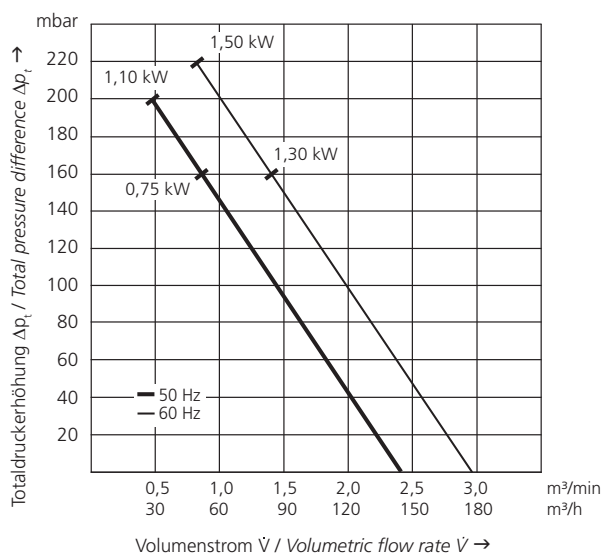

1SE 410

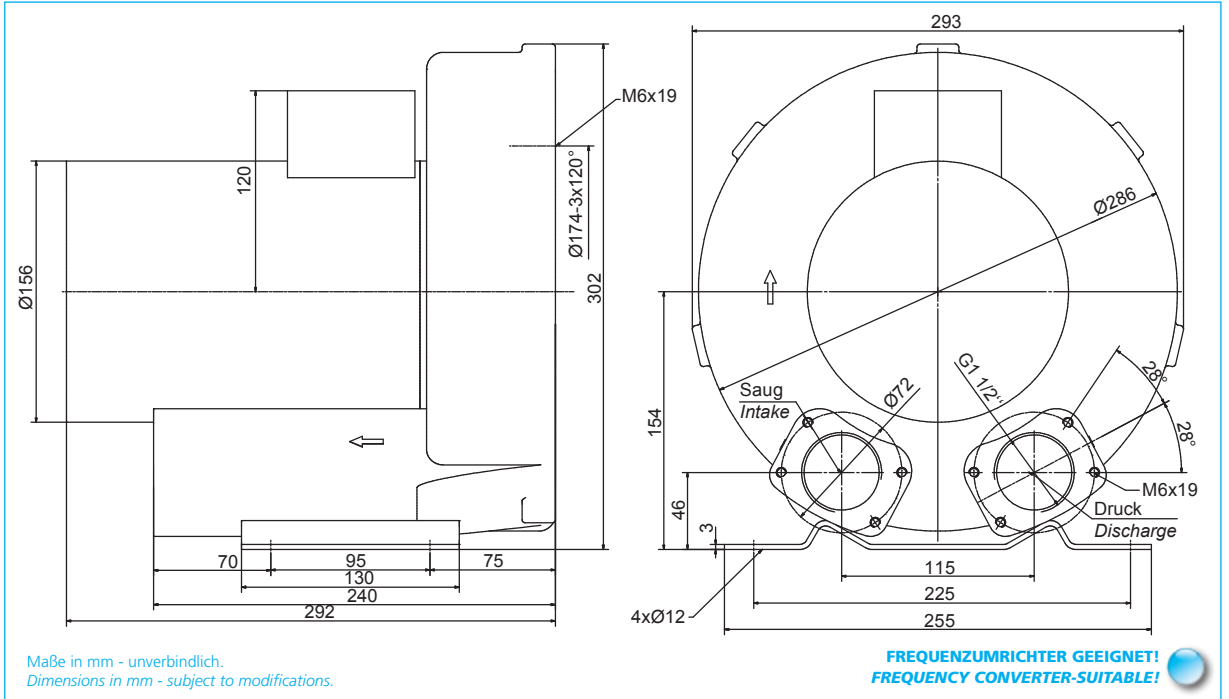

Typ Type	Frequenz Frequency	Grenzwerte der Drosselkurve Überdruck Maximum performance when used as blower		Grenzwerte der Drosselkurve Unterdruck Maximum performance when used as extractor		Nennwerte des Motors Motor ratings			Schalldruckpegel Sound pressure level	Gewicht (ca.) Weight (approx.)
		\dot{V} max. \dot{V} max.	Δp_t max. Δp_t max.	\dot{V} max. \dot{V} max.	Δp_t max. Δp_t max.	Leistung Rated output	Spannung Voltage	Strom Current		
	Hz	m ³ /min	mbar	m ³ /min	mbar	kW	V	A	dB (A)	kg
1SE 410	50	2,42	190	2,42	150	1,10	230	7,30	63	16
	60	2,92	190	2,92	180	1,30	230	8,30	64	16

Überdruck / Pressure

Unterdruck / Vacuum

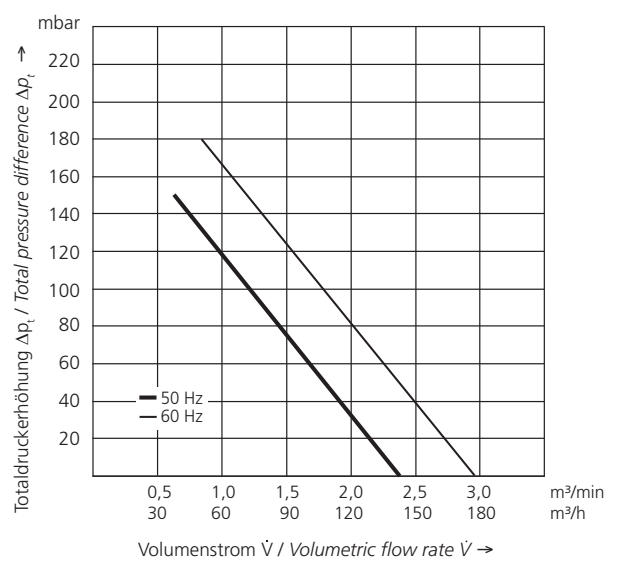
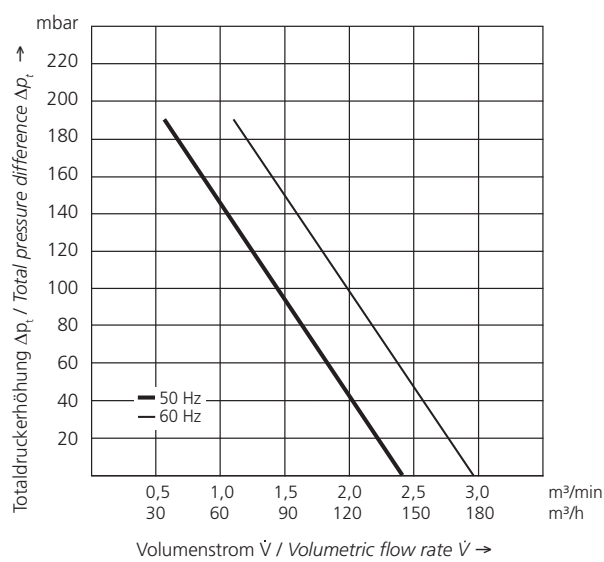

**1SD 410
IE3**

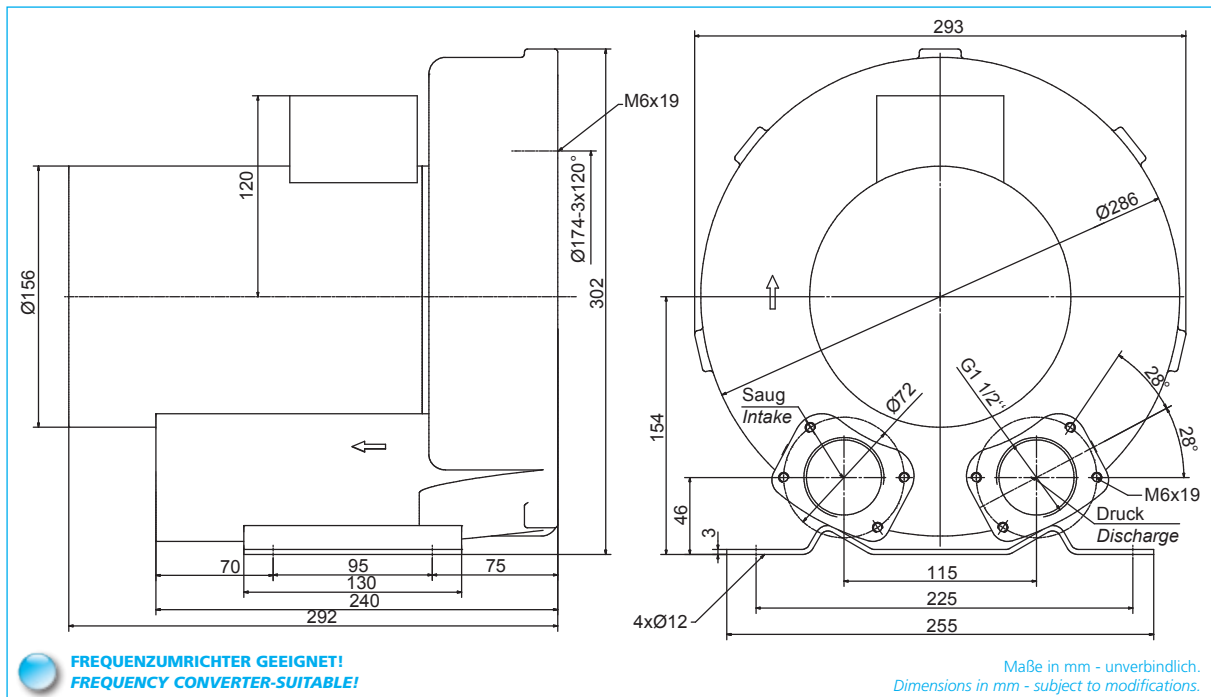

FREQUENZUMRICHTER GEEIGNET!
FREQUENCY CONVERTER-SUITABLE!

Maße in mm - unverbindlich.
Dimensions in mm - subject to modifications.

Typ Type	Effizienzklasse Efficiency class	Frequenz Frequency	Grenzwerte der Drosselkurve Überdruck Maximum performance when used as blower		Grenzwerte der Drosselkurve Unterdruck Maximum performance when used as extractor		Nennwerte des Motors Motor ratings			Schalldruckpegel Sound pressure level	Gewicht (ca.) Weight (approx.)
			\dot{V} max. \dot{V} max.	Δp_t max. Δp_t max.	\dot{V} max. \dot{V} max.	Δp_t max. Δp_t max.	Leistung Rated output	Spannung Voltage	Strom Current		
		Hz	m ³ /min	mbar	m ³ /min	mbar	kW	V	A	dB (A)	kg
1SD 410	IE3	50	2,42	150	2,42	160	0,75	230/400	2,94/1,71	63	19
		60	2,92	140	2,92	140	0,86	480	1,67	64	19
1SD 410	IE3	50	2,42	210	2,42	180	1,10	230/400	4,00/2,31	63	21
		60	2,92	220	2,92	210	1,30	480	2,34	64	21

Überdruck / Pressure

Unterdruck / Vacuum

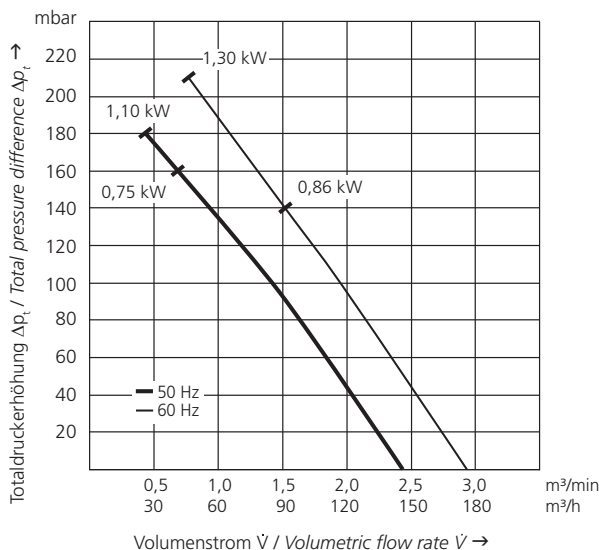
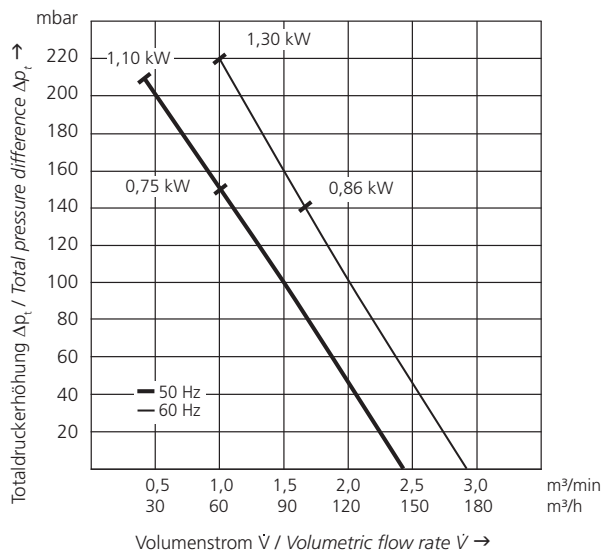

1SD 510



Motor	A	B	C
1,1 kW - 1,5 kW	120	Ø156	315
1,6 kW - 2,2 kW	128	Ø176	346
2,2 kW - 3,8 kW	128	Ø176	372

Maße in mm - unverbindlich.
Dimensions in mm - subject to modifications.

FREQUENZUMRICHTER GEEIGNET!
FREQUENCY CONVERTER-SUITABLE!

Typ	Type	Frequenz Frequency	Grenzwerte der Drosselkurve Überdruck		Grenzwerte der Drosselkurve Unterdruck		Nennwerte des Motors			Schalldruckpegel Sound pressure level	Gewicht (ca.) Weight (approx.)
			\dot{V} max.	Δp_t max.	\dot{V} max.	Δp_t max.	Leistung	Spannung	Strom		
C ^{RU} US			m ³ /min	mbar	m ³ /min	mbar	kW	V	A	dB (A)	kg
1SD 510	✓	50	3,50	170	3,50	170	1,10	207-253/ 360-440	4,35/2,50	64	22
		60	4,25	140	4,25	150	1,50	220-250/ 415-480	5,00/2,90	70	22
1SD 510	✓	50	3,50	190	3,50	200	1,60	207-253/ 360-440	7,50/4,30	64	23
		60	4,25	210	4,25	220	2,20	220-250/ 415-480	8,00/4,60	70	23
1SD 510	✓	50	3,50	270	3,50	220	2,20	207-253/ 360-440	8,10/4,60	64	25
		60	4,25	290	4,25	260	3,80	220-250/ 415-480	13,00/7,50	70	25

Überdruck / Pressure

Unterdruck / Vacuum

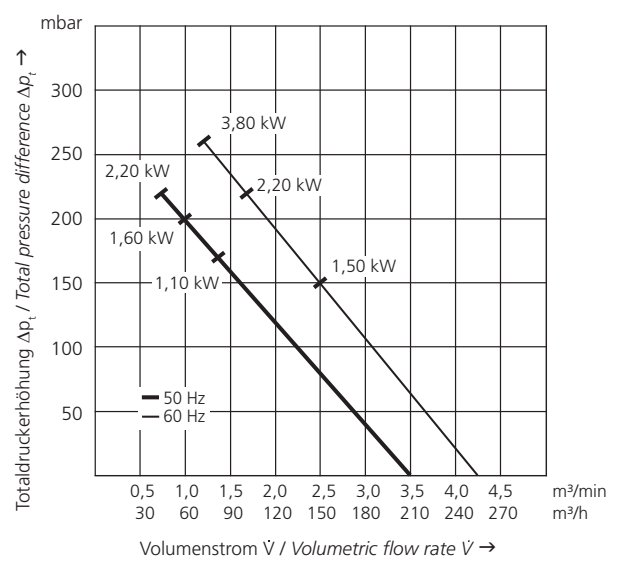
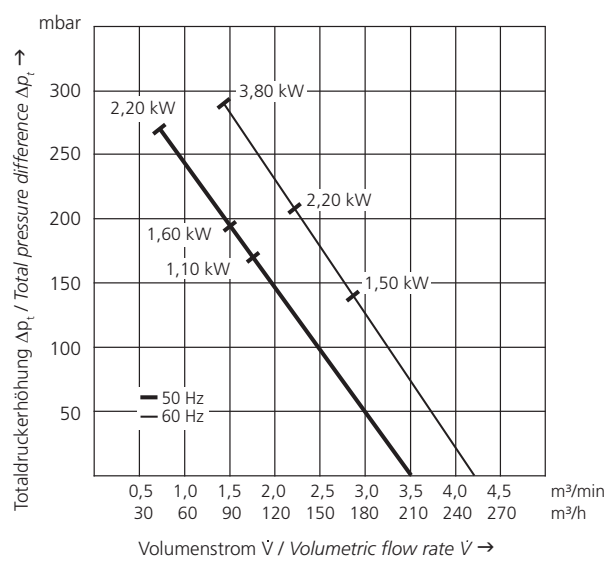

**1SD 510
FU/FUK**

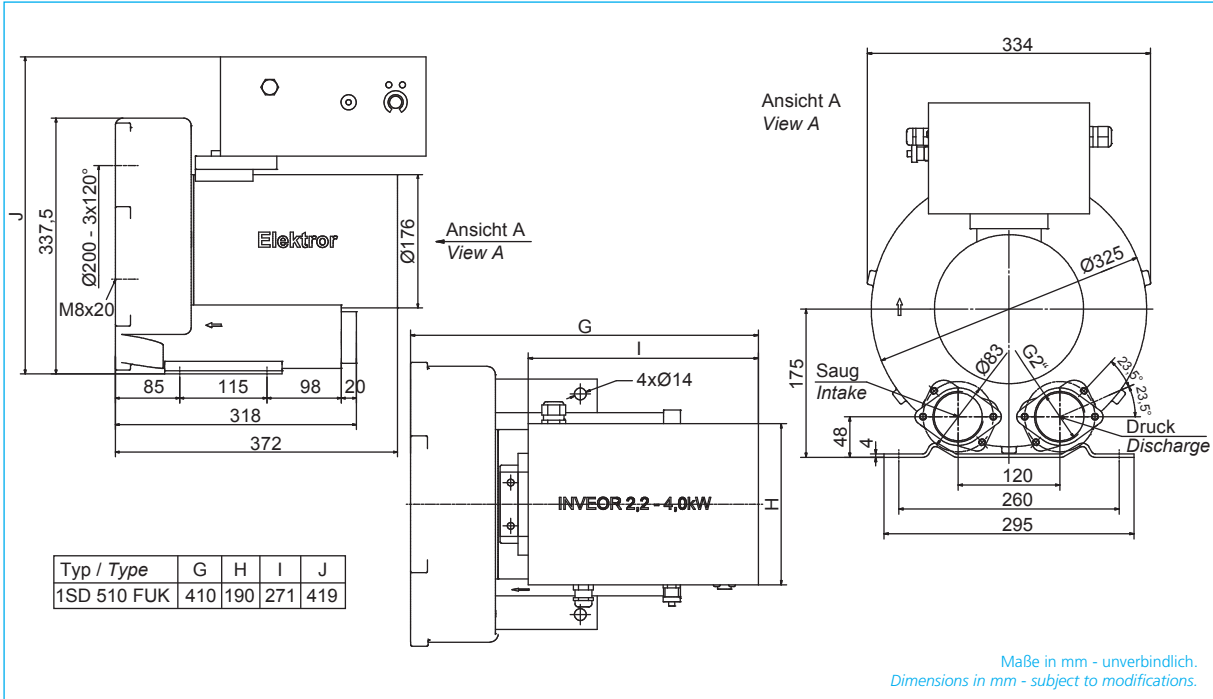
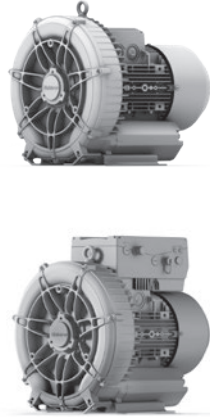

Typ Type	Frequenz Frequency	Grenzwerte der Drosselkurve Überdruck Maximum performance when used as blower		Grenzwerte der Drosselkurve Unterdruck Maximum performance when used as extractor		Nennwerte des Motors Motor ratings			Schalldruckpegel Sound pressure level	Gewicht (ca.) Weight (approx.)
		\dot{V}_{max}	$\Delta p_t \text{ max.}$	\dot{V}_{max}	$\Delta p_t \text{ max.}$	Leistung Rated output	Spannung Voltage	Strom Current		
		Hz	m ³ /min	mbar	m ³ /min	mbar	kW	V		
1SD 510 FUK	80	5,40	300	5,20	300	3,80	400 Δ	7,50	84	30
1SD 510 FU	80	5,40	300	5,20	300	3,80	400 Δ	7,50	84	28

Überdruck / Pressure

Unterdruck / Vacuum

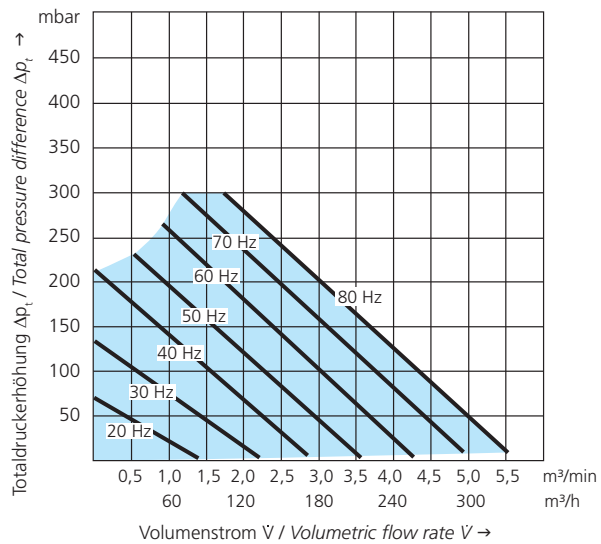
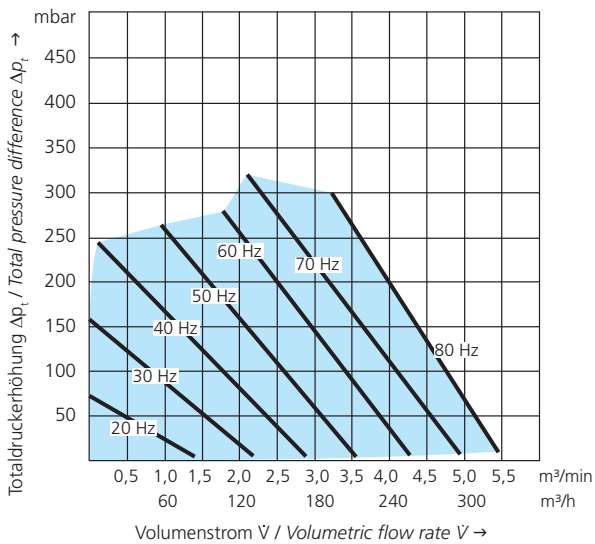

**1SD 510
IE3**

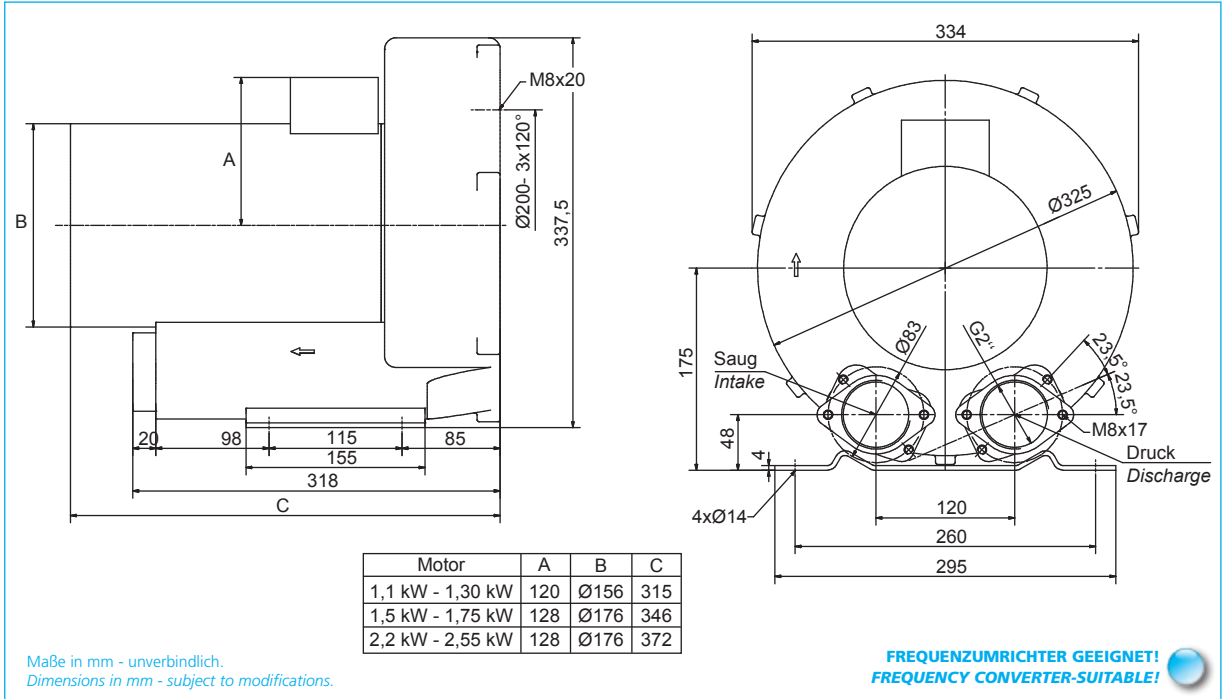

Typ Type	Effizienzklasse Efficiency class	Frequenz Frequency	Grenzwerte der Drosselkurve Überdruck Maximum performance when used as blower		Grenzwerte der Drosselkurve Unterdruck Maximum performance when used as extractor		Nennwerte des Motors Motor ratings			Schalldruckpegel Sound pressure level	Gewicht (ca.) Weight (approx.)
			\dot{V} max. \dot{V} max.	Δp_t max. Δp_t max.	\dot{V} max. \dot{V} max.	Δp_t max. Δp_t max.	Leistung Rated output	Spannung Voltage	Strom Current		
		Hz	m ³ /min	mbar	m ³ /min	mbar	kW	V	A	dB (A)	kg
1SD 510	IE3	50	3,50	150	3,50	150	1,10	230/400	4,00/2,31	64	29
		60	4,25	130	4,25	140	1,30	480	2,34	70	29
1SD 510	IE3	50	3,50	220	3,50	230	1,50	230/400	5,20/3,00	64	32
		60	4,25	200	4,25	210	1,75	480	2,90	70	32
1SD 510	IE3	50	3,50	310	3,50	250	2,20	230/400	7,53/4,35	64	40
		60	4,25	320	4,25	280	2,55	480	4,17	70	40

Überdruck / Pressure

Unterdruck / Vacuum

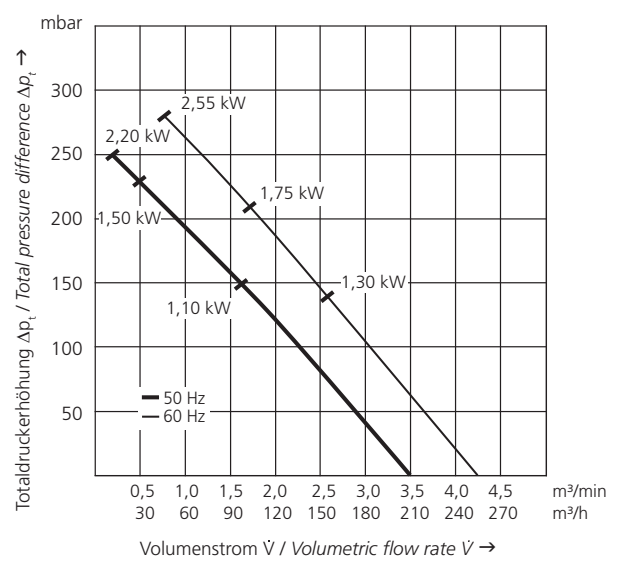
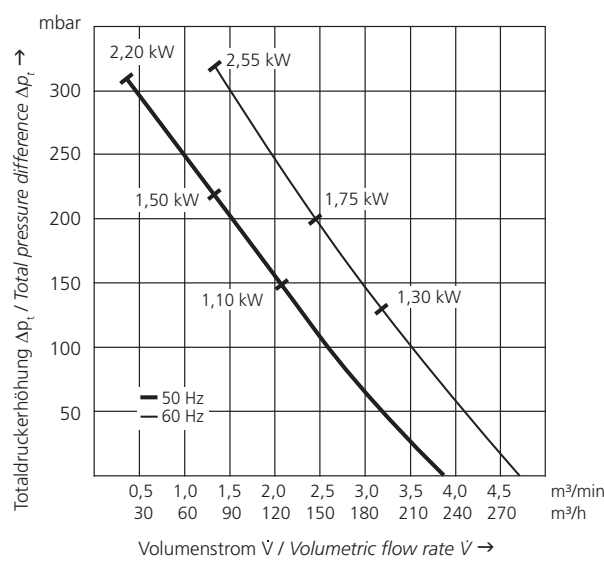

1SD 710

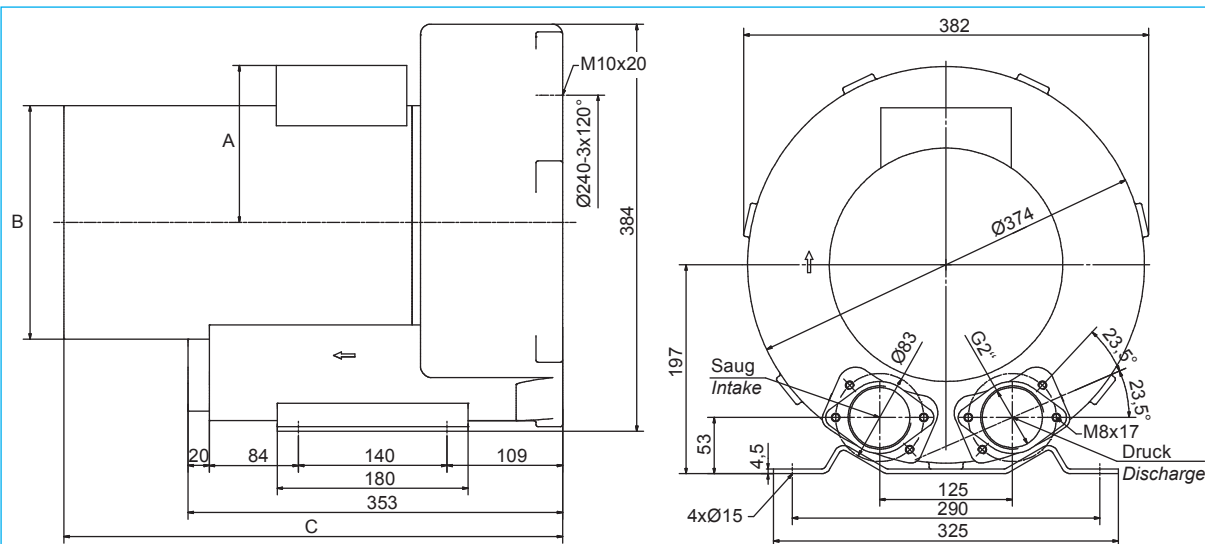

Motor	A	B	C
2,2 kW - 3,8 kW	128	Ø176	431
3,0 kW - 4,6 kW	135	Ø220	446
4,0 kW - 6,0 kW	148	Ø220	470

FREQUENZUMRICHTER GEEIGNET!
FREQUENCY CONVERTER-SUITABLE!

Maße in mm - unverbindlich.
Dimensions in mm - subject to modifications.

Typ Type	✓	Frequenz Frequency	Grenzwerte der Drosselkurve Überdruck Maximum performance when used as blower		Grenzwerte der Drosselkurve Unterdruck Maximum performance when used as extractor		Nennwerte des Motors Motor ratings			Schalldruckpegel Sound pressure level	Gewicht (ca.) Weight (approx.)
			\dot{V} max.	Δp_t max.	\dot{V} max.	Δp_t max.	Leistung Rated output	Spannung Voltage	Strom Current		
			\dot{V} max.	Δp_t max.	\dot{V} max.	Δp_t max.					
1SD 710	✓	50	5,30	200	5,30	210	2,20	207-253/ 360-440	8,10/4,60	69	30
		60	6,27	200	6,27	210	3,80	220-250/ 415-480	13,00/7,50	72	30
1SD 710	✓	50	5,30	290	5,30	270	3,00	207-253/ 360-440	12,50/7,20	69	36
		60	6,27	230	6,27	250	4,60	220-250/ 415-480	14,70/8,50	72	36
1SD 710	✓	50	5,30	330	5,30	290	4,00	360-440	9,00	69	42
		60	6,27	330	6,27	330	6,00	415-480	10,90	72	42

Überdruck / Pressure

Unterdruck / Vacuum

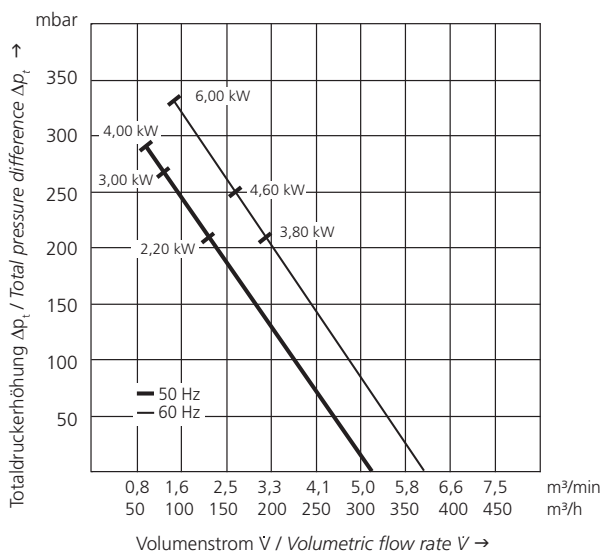
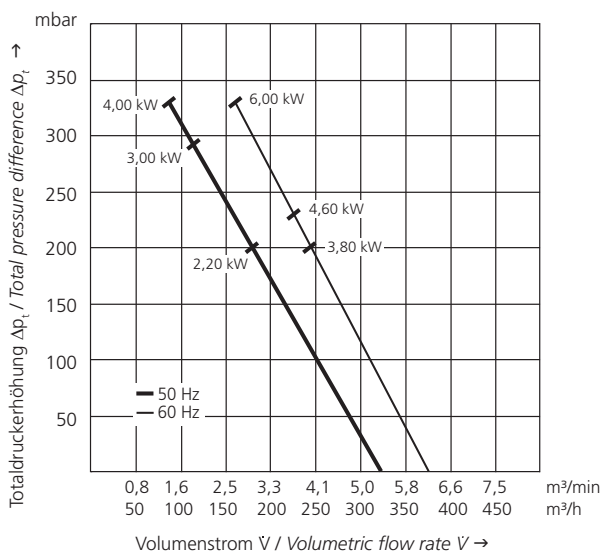

**1SD 710
IE3**



Motor	A	B	C
2,2 kW - 2,55 kW	128	Ø176	431
3,0 kW - 3,46 kW	135	Ø220	446
4,0 kW - 4,60 kW	148	Ø220	470

Maße in mm - unverbindlich.
Dimensions in mm - subject to modifications.

**FREQUENZUMRICHTER GEEIGNET!
FREQUENCY CONVERTER-SUITABLE!**

Typ Type	Effizienzklasse Efficiency class	Frequenz Frequency	Grenzwerte der Drosselkurve Überdruck Maximum performance when used as blower		Grenzwerte der Drosselkurve Unterdruck Maximum performance when used as extractor		Nennwerte des Motors Motor ratings			Schalldruckpegel Sound pressure level	Gewicht (ca.) Weight (approx.)
			\dot{V} max. \dot{V} max.	Δp_t max. Δp_t max.	\dot{V} max. \dot{V} max.	Δp_t max. Δp_t max.	Leistung Rated output	Spannung Voltage	Strom Current		
		Hz	m ³ /min	mbar	m ³ /min	mbar	kW	V	A	dB (A)	kg
1SD 710	IE3	50	5,30	190	5,30	200	2,20	230/400	7,53/4,35	69	49
		60	6,27	180	6,27	190	2,55	480	4,17	72	49
1SD 710	IE3	50	5,30	280	5,30	280	3,00	230/400	9,90/5,70	69	54
		60	6,27	270	6,27	280	3,46	480	5,40	72	54
1SD 710	IE3	50	5,30	350	5,30	290	4,00	400/690	7,45/4,30	69	63
		60	6,27	360	6,27	330	4,60	480	7,40	72	63

Überdruck / Pressure

Unterdruck / Vacuum

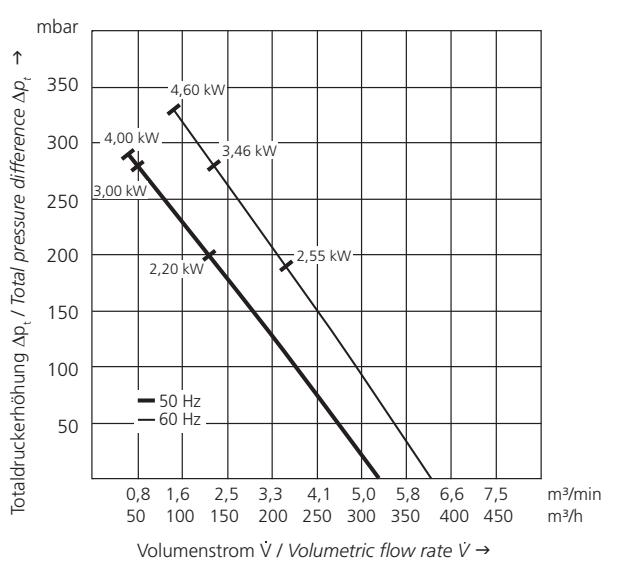
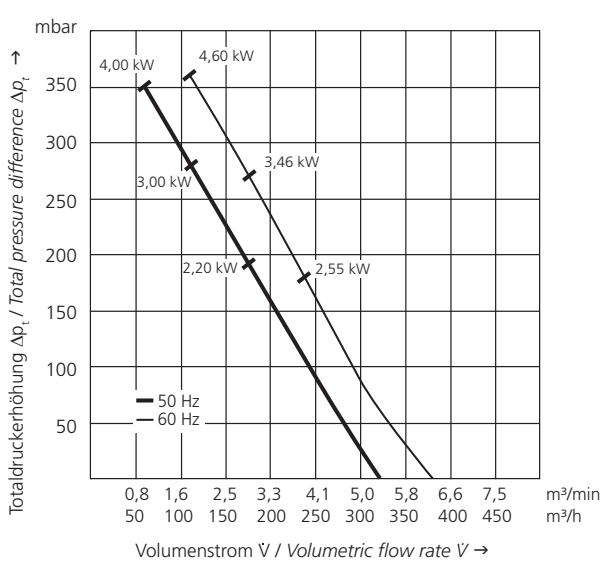

1SD 810

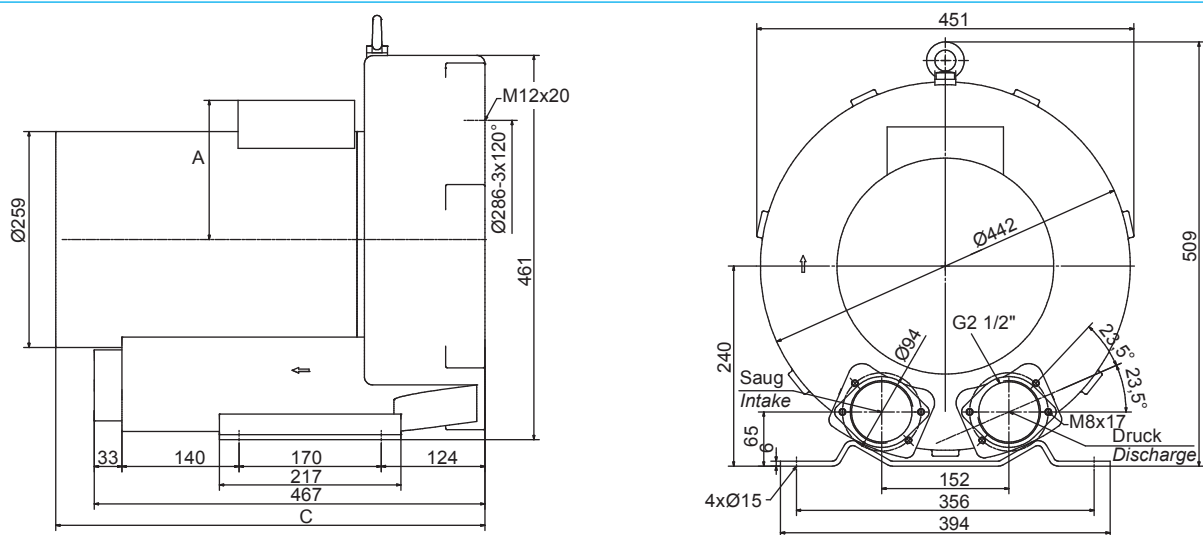

Motor	A	B	C
4,0 kW - 6,0 kW	148	Ø220	490
5,5 kW - 8,6 kW	167	Ø259	480
7,5 kW - 9,8 kW	167	Ø259	513

FREQUENZUMRICHTER GEEIGNET!
FREQUENCY CONVERTER-SUITABLE!

Maße in mm - unverbindlich.
Dimensions in mm - subject to modifications.

Typ	Type	Frequenz Frequency	Grenzwerte der Drosselkurve Überdruck		Grenzwerte der Drosselkurve Unterdruck		Nennwerte des Motors			Schalldruckpegel Sound pressure level	Gewicht (ca.) Weight (approx.)
			\dot{V} max.	Δp_t max.	\dot{V} max.	Δp_t max.	Leistung	Spannung	Strom		
		Hz	m ³ /min	mbar	m ³ /min	mbar	kW	V	A	dB (A)	kg
1SD 810	✓	50	8,83	200	8,83	200	4,0	360-440	9,00	70	54
		60	10,33	160	10,33	160	6,0	415-480	10,90	74	54
1SD 810	✓	50	8,83	300	8,83	300	5,5	360-440	13,30	70	63
		60	10,33	280	10,33	300	8,6	415-480	15,30	74	63
1SD 810	✓	50	8,83	430	8,83	320	7,5	360-440	16,70	70	66
		60	10,33	400	10,33	350	9,8	415-480	18,20	74	66

Überdruck / Pressure

Unterdruck / Vacuum

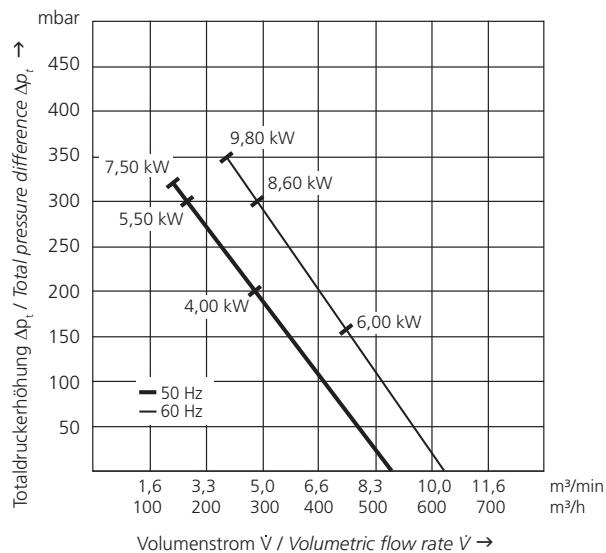
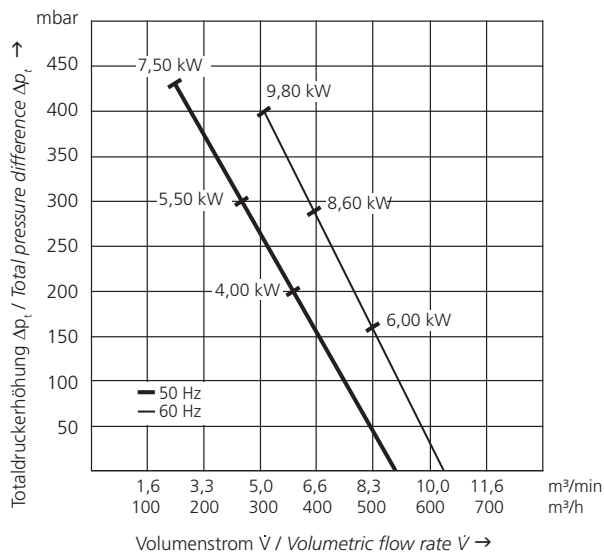

1SD 810
IE3



Motor	A	B	C
4,0 kW - 4,6 kW	148	Ø220	490
5,5 kW - 6,3 kW	167	Ø259	480
7,5 kW - 8,6 kW	167	Ø259	513

Maße in mm - unverbindlich.
Dimensions in mm - subject to modifications.

FREQUENZUMRICHTER GEEIGNET!
FREQUENCY CONVERTER-SUITABLE!

Typ Type	Effizienzklasse Efficiency class	Frequenz Frequency	Grenzwerte der Drosselkurve Überdruck Maximum performance when used as blower		Grenzwerte der Drosselkurve Unterdruck Maximum performance when used as extractor		Nennwerte des Motors Motor ratings			Schalldruckpegel Sound pressure level	Gewicht (ca.) Weight (approx.)
			\dot{V} max. \dot{V} max.	Δp_t max. Δp_t max.	\dot{V} max. \dot{V} max.	Δp_t max. Δp_t max.	Leistung Rated output	Spannung Voltage	Strom Current		
		Hz	m ³ /min	mbar	m ³ /min	mbar	kW	V	A	dB (A)	kg
1SD 810	IE3	50	8,83	180	8,83	200	4,00	400/690	7,45/4,30	70	62
		60	10,33	150	10,33	160	4,60	480	7,40	74	62
1SD 810	IE3	50	8,83	300	8,83	300	5,50	400/690	10,10/5,83	70	73
		60	10,33	250	10,33	270	6,30	480	9,60	74	73
1SD 810	IE3	50	8,83	420	8,83	340	7,50	400/690	13,50/7,80	70	77
		60	10,33	400	10,33	350	8,60	480	12,90	74	77

Überdruck / Pressure

Unterdruck / Vacuum

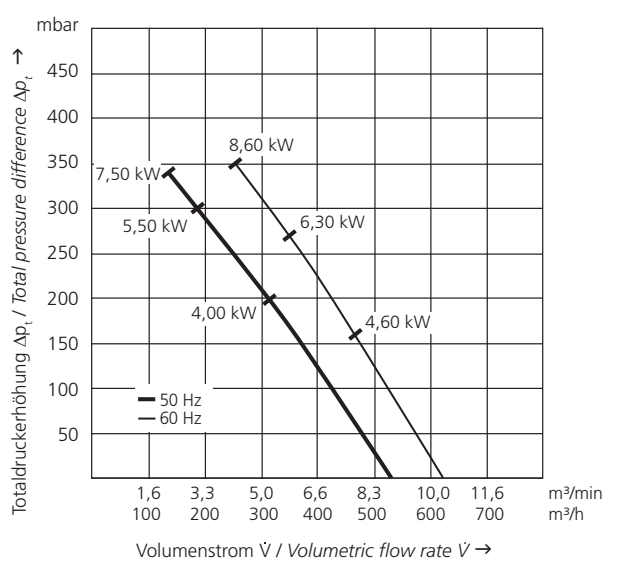
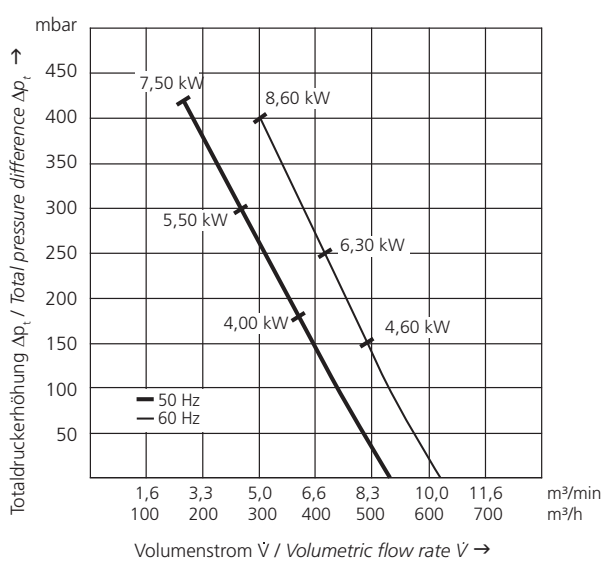

1SD 910

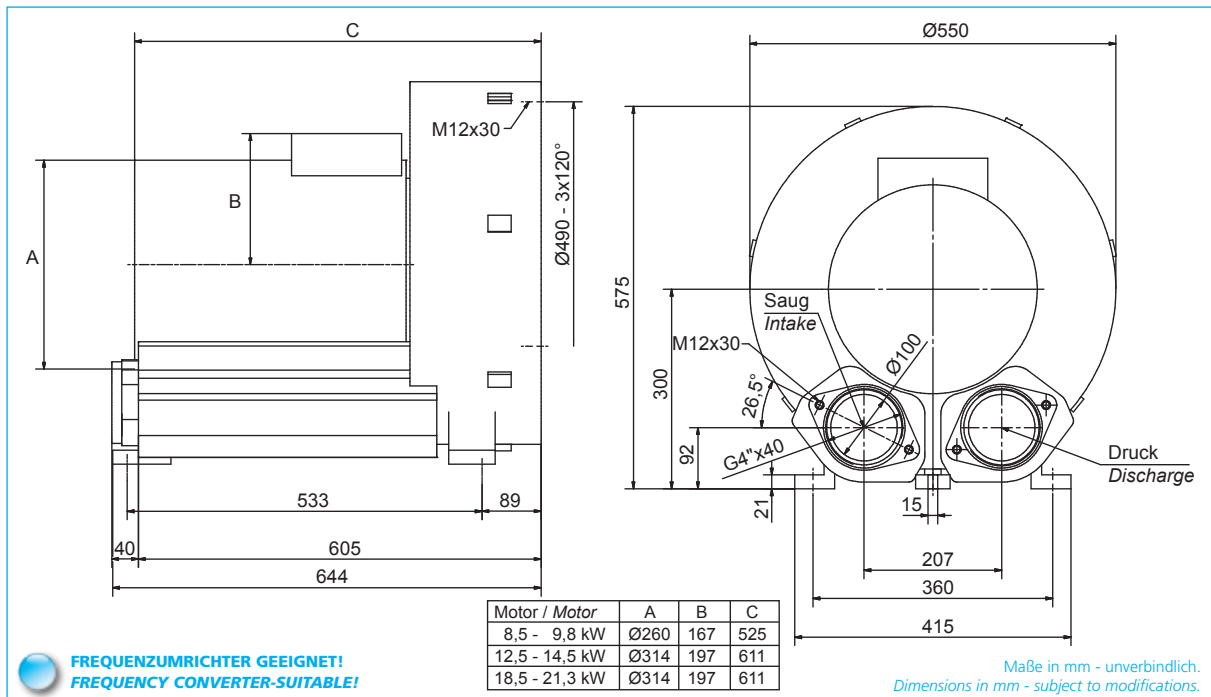

FREQUENZUMRICHTER GEEIGNET!
FREQUENCY CONVERTER-SUITABLE!

Typ Type	Frequenz Frequency	Grenzwerte der Drosselkurve Überdruck Maximum performance when used as blower		Grenzwerte der Drosselkurve Unterdruck Maximum performance when used as extractor		Nennwerte des Motors Motor ratings			Schalldruckpegel Sound pressure level	Gewicht (ca.) Weight (approx.)
		\dot{V}_{max} \dot{V}_{max}	Δp_t max. Δp_t max.	\dot{V}_{max} \dot{V}_{max}	Δp_t max. Δp_t max.	Leistung Rated output	Spannung Voltage	Strom Current		
	Hz	m ³ /min	mbar	m ³ /min	mbar	kW	V	A	dB (A)	kg
1SD 910 ✓	50	17,50	190	17,5	210	8,50	360-440	18,20	74	93
	60	20,80	140	20,8	180	9,80	415-480	18,20	84	93
1SD 910 ✓	50	17,50	280	17,5	280	12,50	360-440	28,00	75	116
	60	20,80	260	20,8	270	14,50	415-480	26,00	84	116
1SD 910 ✓	50	17,50	460	17,5	360	18,50	360-440	37,00	75	126
	60	20,80	420	20,8	380	21,30	415-480	36,50	84	126

Überdruck / Pressure

Unterdruck / Vacuum

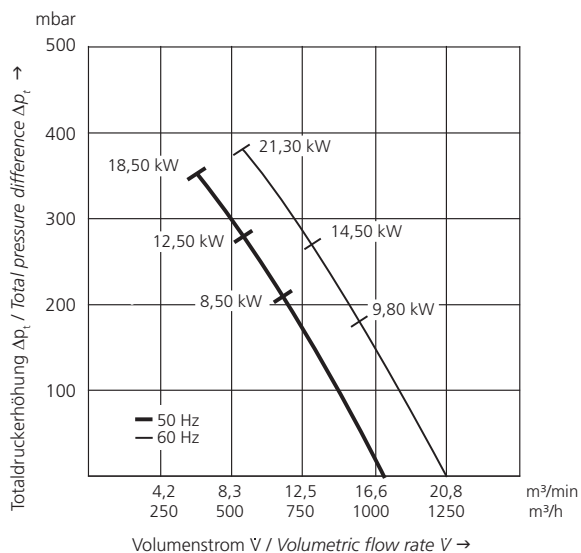
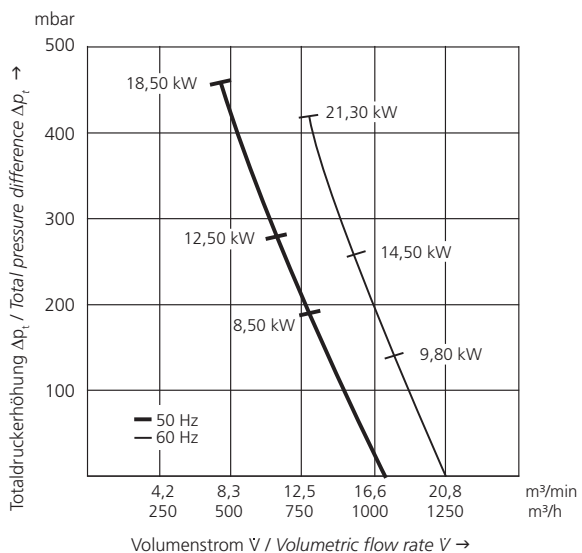

1SD 910
IE3

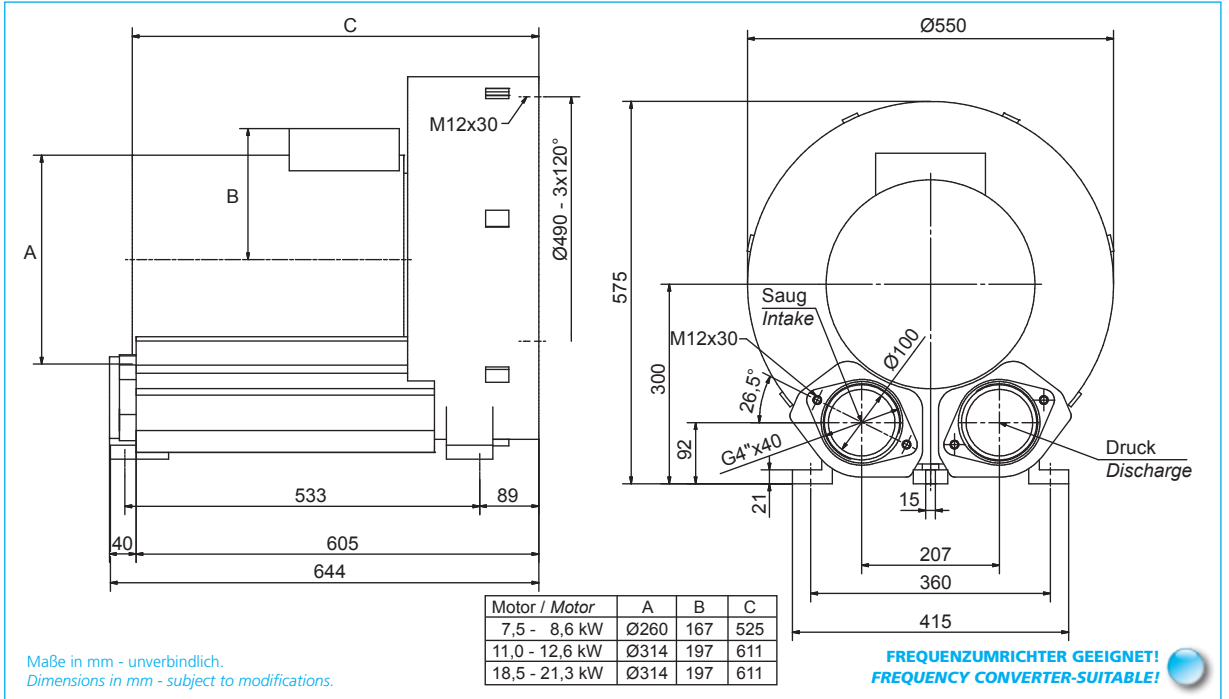

Typ Type	Effizienzklasse Efficiency class	Frequenz Frequency	Grenzwerte der Drosselkurve Überdruck Maximum performance when used as blower		Grenzwerte der Drosselkurve Unterdruck Maximum performance when used as extractor		Nennwerte des Motors Motor ratings			Schalldruckpegel Sound pressure level	Gewicht (ca.) Weight (approx.)
			\dot{V} max. \dot{V} max.	Δp_t max. Δp_t max.	\dot{V} max. \dot{V} max.	Δp_t max. Δp_t max.	Leistung Rated output	Spannung Voltage	Strom Current		
		Hz	m ³ /min	mbar	m ³ /min	mbar	kW	V	A	dB (A)	kg
1SD 910	IE3	50	17,50	190	17,50	200	7,50	400/690	13,50/7,80	74	118
		60	20,80	160	20,80	170	8,60	480	12,90	84	118
1SD 910	IE3	50	17,50	280	17,50	290	11,00	400/690	19,60/11,30	75	140
		60	20,80	260	20,80	270	12,60	480	18,70	84	140
1SD 910	IE3	50	17,50	500	17,50	350	18,50	400/690	32,50/18,80	75	162
		60	20,80	460	20,80	380	21,30	480	32,40	84	162

Überdruck / Pressure

Unterdruck / Vacuum

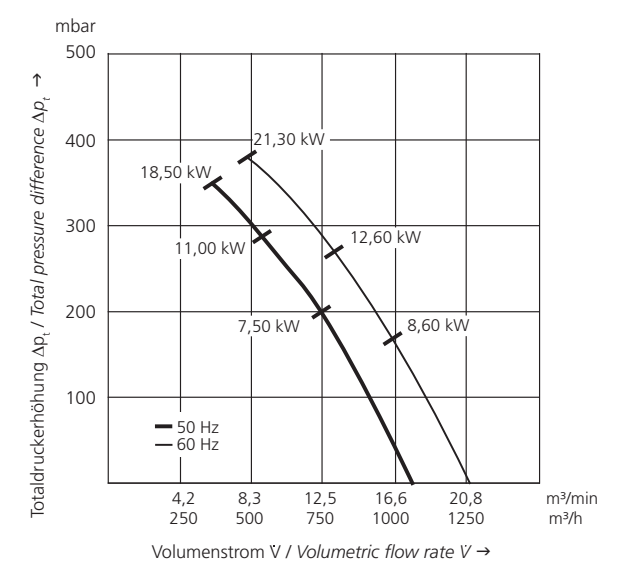
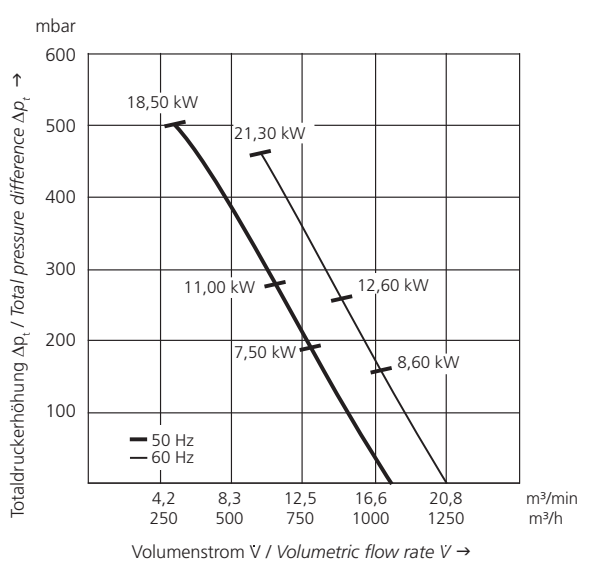

2SD 220

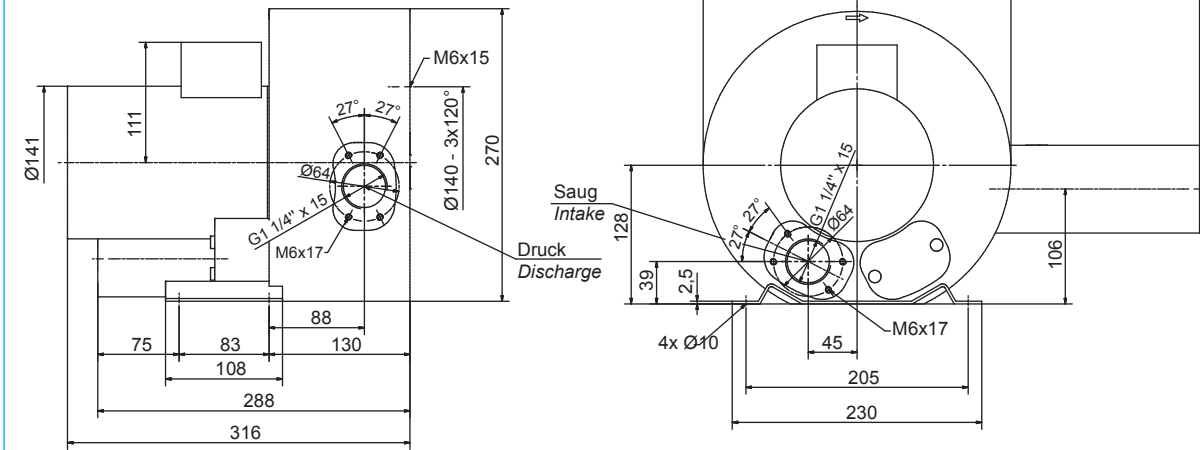
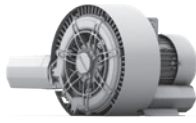

FREQUENZUMRICHTER GEEIGNET!
FREQUENCY CONVERTER-SUITABLE!

Maße in mm - unverbindlich.
Dimensions in mm - subject to modifications.

Typ Type	Frequenz Frequency	Grenzwerte der Drosselkurve Überdruck Maximum performance when used as blower		Grenzwerte der Drosselkurve Unterdruck Maximum performance when used as extractor		Nennwerte des Motors Motor ratings			Schalldruckpegel Sound pressure level	Gewicht (ca.) Weight (approx.)
		\dot{V} max. \dot{V} max.	Δp_t max. Δp_t max.	\dot{V} max. \dot{V} max.	Δp_t max. Δp_t max.	Leistung Rated output	Spannung Voltage	Strom Current		
	Hz	m ³ /min	mbar	m ³ /min	mbar	kW	V	A	dB (A)	kg
2SD 220 ✓	50	1,47	240	1,47	210	0,55	207-253/ 360-440	2,70/1,57	55	14
	60	1,72	250	1,72	250	0,94	220-250/ 415-480	4,00/2,30	61	14

Überdruck / Pressure

Unterdruck / Vacuum

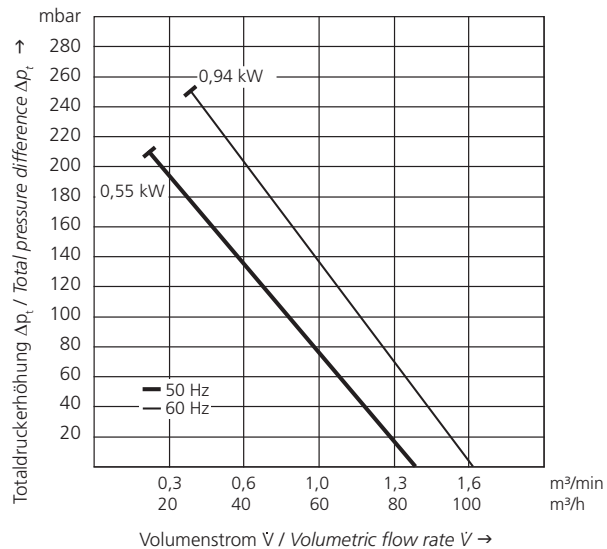
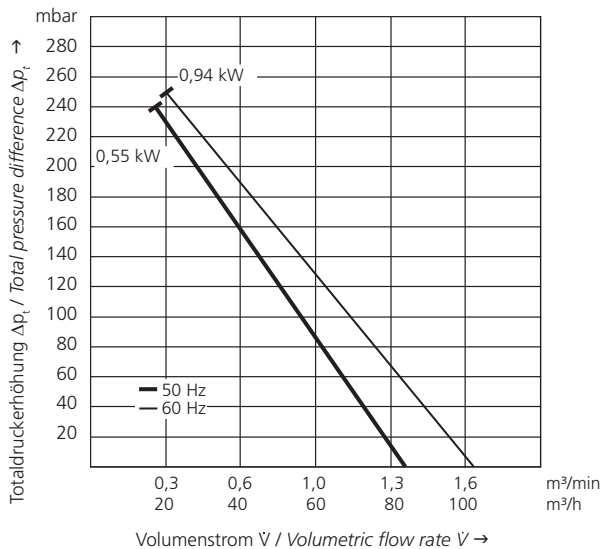

2SD 320

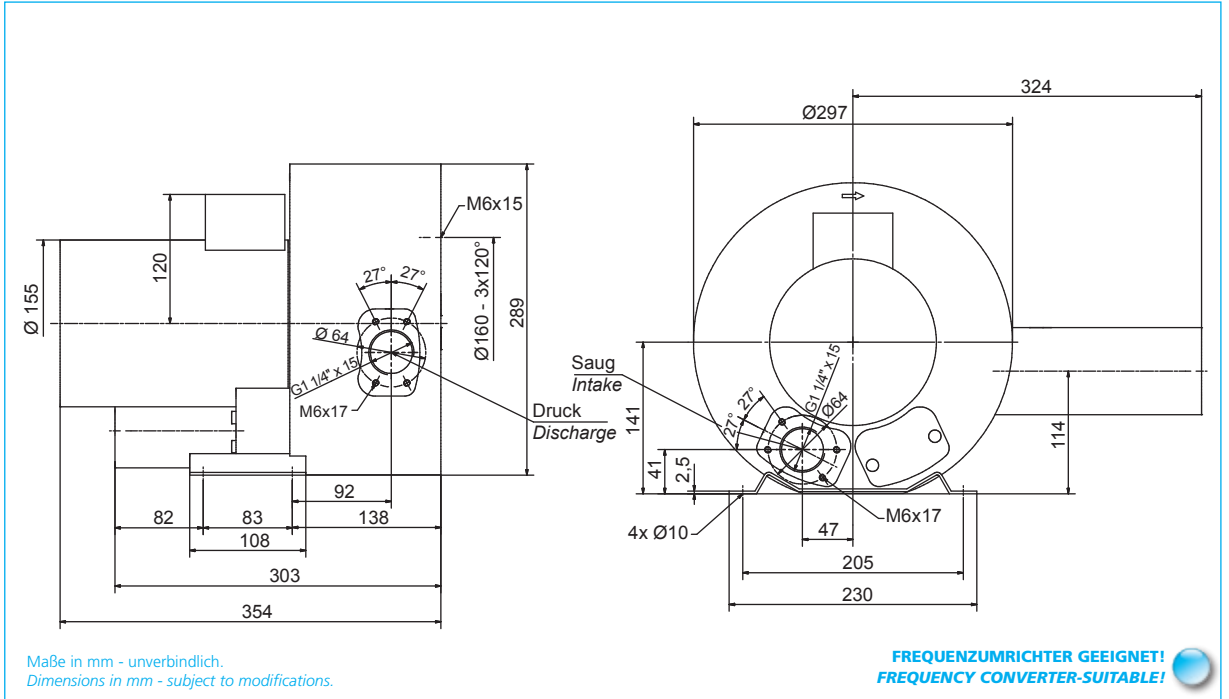
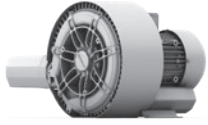

Typ Type	Frequenz Frequency	Grenzwerte der Drosselkurve Überdruck Maximum performance when used as blower		Grenzwerte der Drosselkurve Unterdruck Maximum performance when used as extractor		Nennwerte des Motors Motor ratings			Schalldruckpegel Sound pressure level	Gewicht (ca.) Weight (approx.)
		\dot{V} max. \dot{V} max.	Δp_t max. Δp_t max.	\dot{V} max. \dot{V} max.	Δp_t max. Δp_t max.	Leistung Rated output	Spannung Voltage	Strom Current		
	Hz	m ³ /min	mbar	m ³ /min	mbar	kW	V	A	dB (A)	kg
2SD 320 ✓	50	2,00	290	2,00	280	1,10	207-253/ 360-440	4,35/2,50	58	18
	60	2,42	400	2,42	300	1,50	220-250/ 415-480	5,00/2,90	60	18

Überdruck / Pressure

Unterdruck / Vacuum

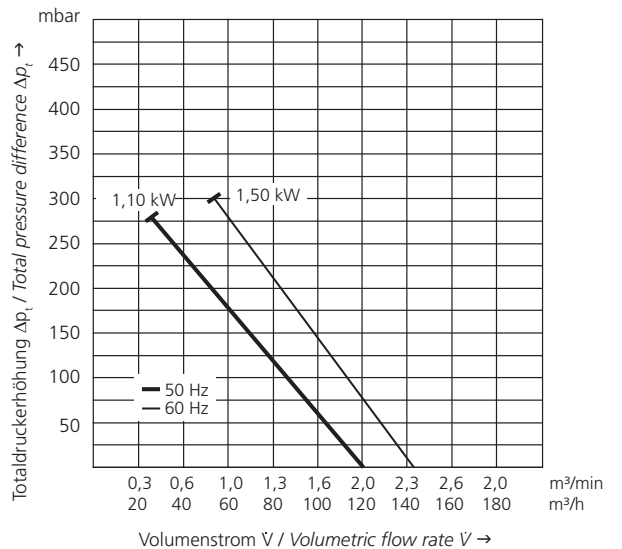
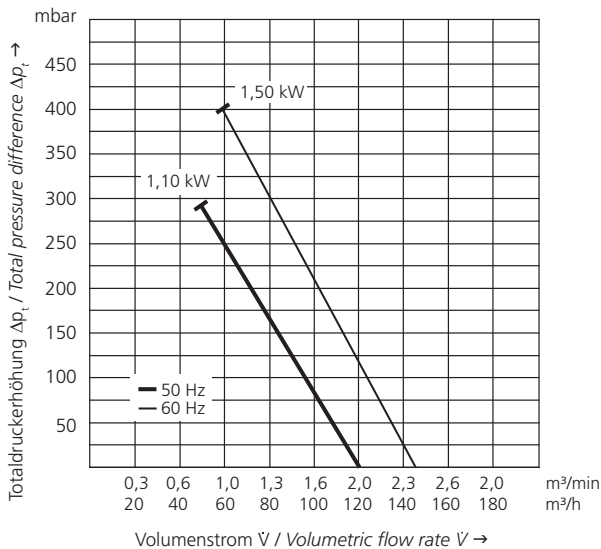

2SD 420

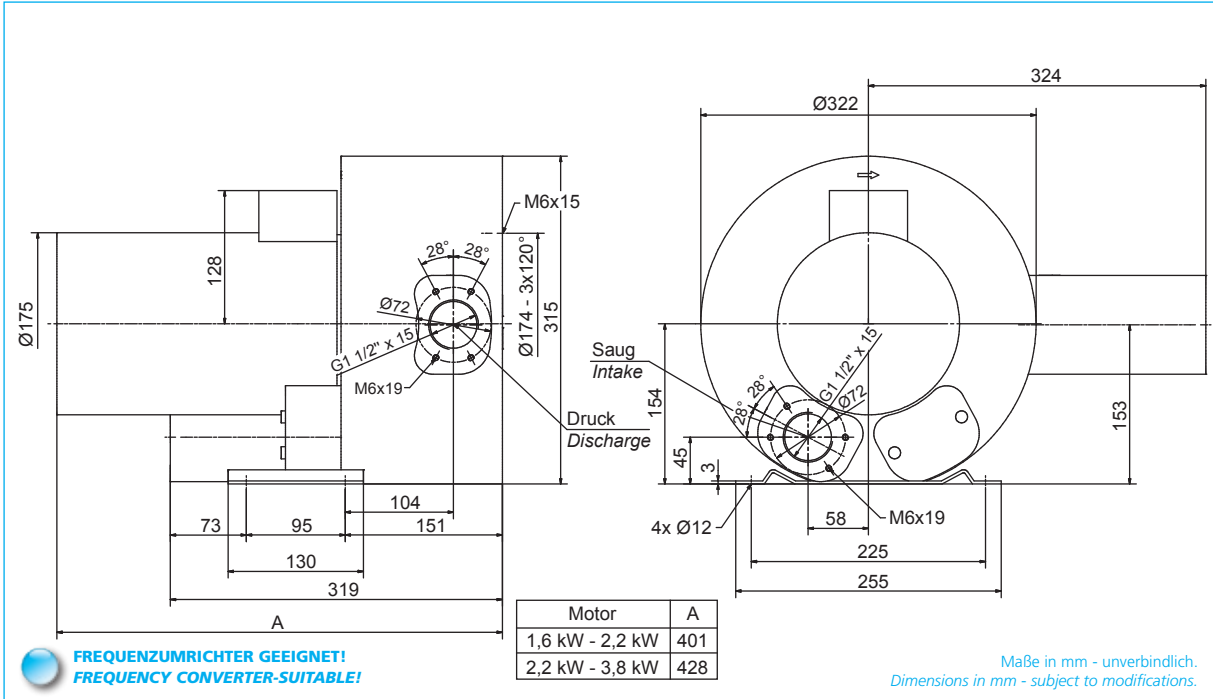

Typ	Type	Frequenz Frequency	Grenzwerte der Drosselkurve Überdruck		Grenzwerte der Drosselkurve Unterdruck		Nennwerte des Motors			Schalldruckpegel Sound pressure level	Gewicht (ca.) Weight (approx.)
			\dot{V} max.	Δp_t max.	\dot{V} max.	Δp_t max.	Leistung	Spannung	Strom		
		Hz	\dot{V} max.	Δp_t max.	\dot{V} max.	Δp_t max.	Rated output	Voltage	Current	dB (A)	kg
2SD 420	✓	50	2,50	280	2,50	280	1,60	207-253/ 360-440	7,50/4,30	66	25
		60	3,00	310	3,00	320	2,20	220-250/ 415-480	8,00/4,60	69	25
2SD 420	✓	50	2,50	440	2,50	330	2,20	207-253/ 360-440	9,70/5,60	66	27
		60	3,00	420	3,00	350	3,80	220-250/ 415-480	13,00/7,50	69	27

Überdruck / Pressure

Unterdruck / Vacuum

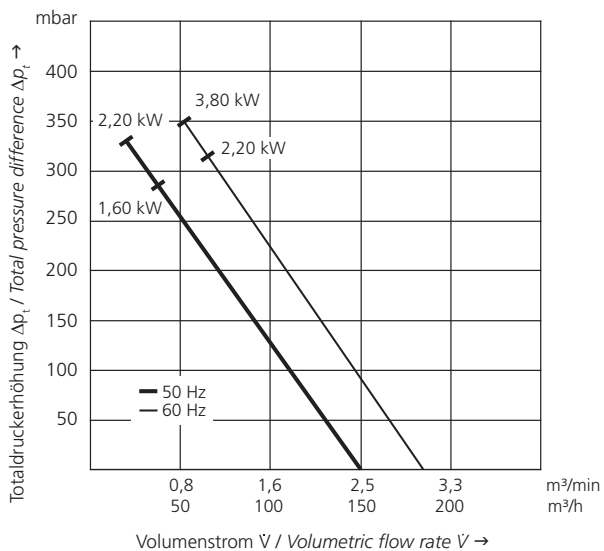
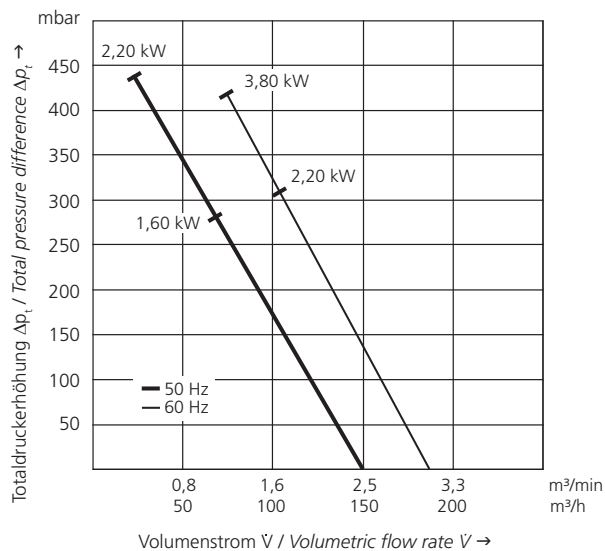

2SD 420
IE3

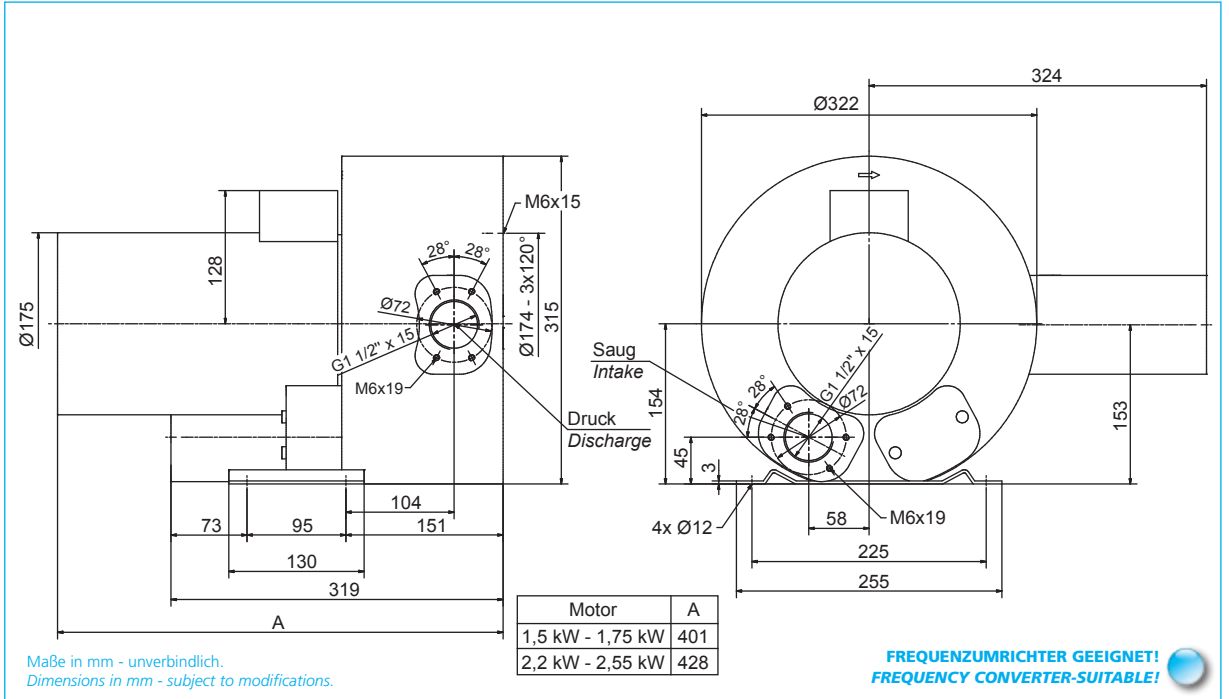

Typ Type	Effizienzklasse Efficiency class	Frequenz Frequency	Grenzwerte der Drosselkurve Überdruck Maximum performance when used as blower		Grenzwerte der Drosselkurve Unterdruck Maximum performance when used as extractor		Nennwerte des Motors Motor ratings			Schalldruckpegel Sound pressure level	Gewicht (ca.) Weight (approx.)
			\dot{V} max. \dot{V} max.	Δp_t max. Δp_t max.	\dot{V} max. \dot{V} max.	Δp_t max. Δp_t max.	Leistung Rated output	Spannung Voltage	Strom Current		
		Hz	m ³ /min	mbar	m ³ /min	mbar	kW	V	A	dB (A)	kg
2SD 420	IE3	50	2,50	310	2,50	320	1,50	230/400	5,20/3,00	66	32
		60	3,00	280	3,00	300	1,75	480	2,90	69	32
2SD 420	IE3	50	2,50	420	2,50	320	2,20	230/400	7,53/4,35	66	35
		60	3,00	470	3,00	400	2,55	480	4,17	69	35

Überdruck / Pressure

Unterdruck / Vacuum

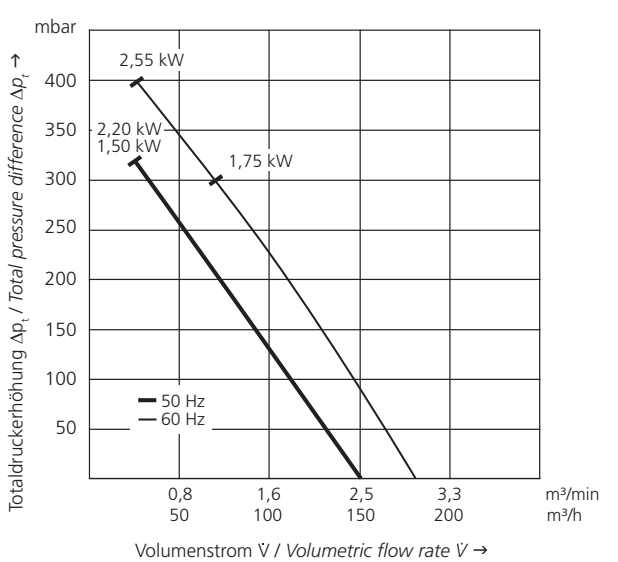
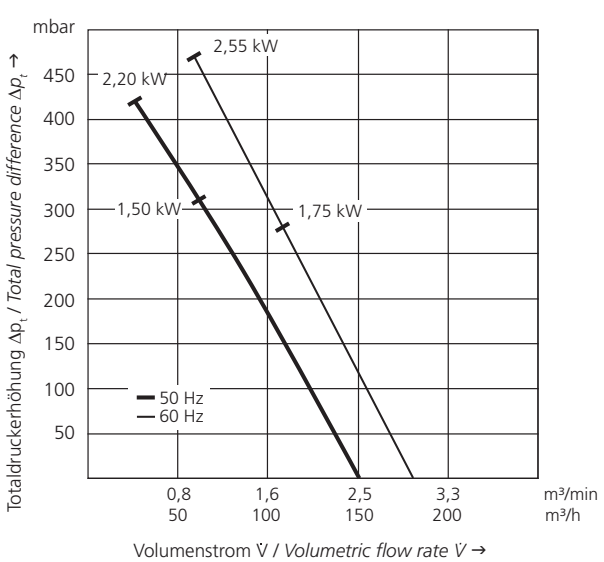

2SD 520

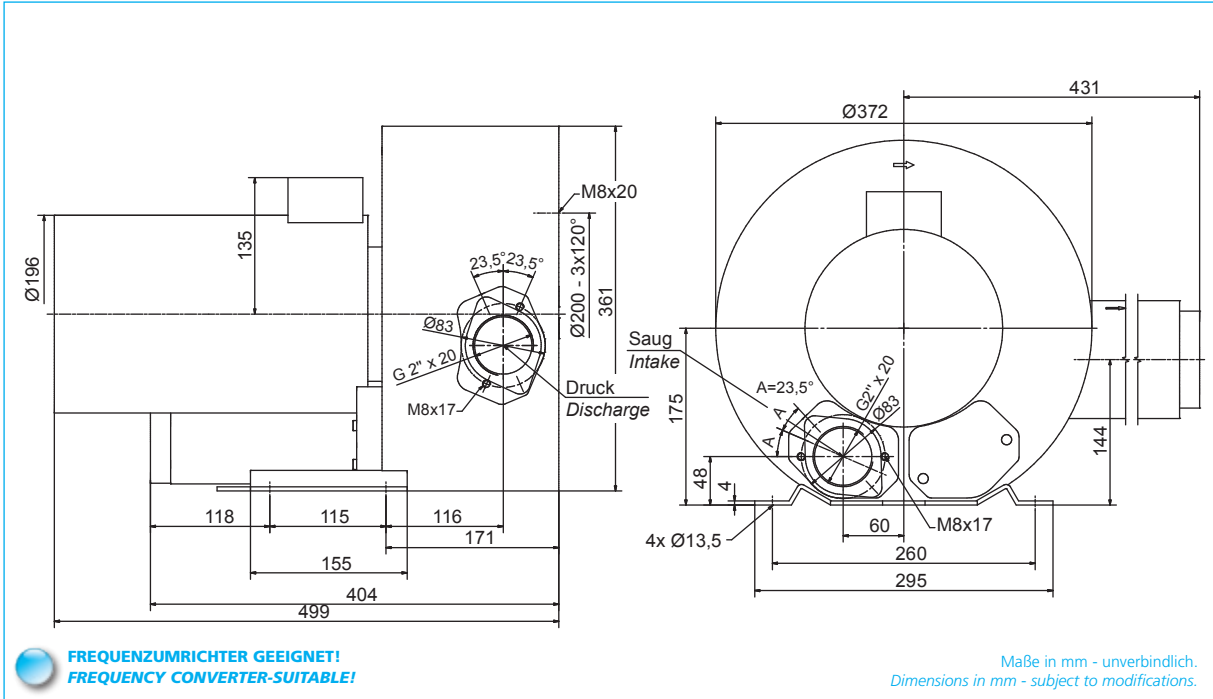
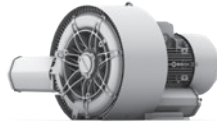

Typ Type	Frequenz Frequency	Grenzwerte der Drosselkurve Überdruck Maximum performance when used as blower		Grenzwerte der Drosselkurve Unterdruck Maximum performance when used as extractor		Nennwerte des Motors Motor ratings			Schalldruckpegel Sound pressure level	Gewicht (ca.) Weight (approx.)
		\dot{V} max. \dot{V} max.	Δp_t max. Δp_t max.	\dot{V} max. \dot{V} max.	Δp_t max. Δp_t max.	Leistung Rated output	Spannung Voltage	Strom Current		
	Hz	m ³ /min	mbar	m ³ /min	mbar	kW	V	A	dB (A)	kg
2SD 520 ✓	50	3,83	410	3,83	340	3,00	207-253/ 360-440	12,50/7,20	72	39
	60	4,58	360	4,58	380	4,60	220-250/ 415-480	14,70/8,50	74	39
2SD 520 ✓	50	3,83	440	3,83	390	4,00	360-440	10,00	72	44
	60	4,58	480	4,58	410	6,00	415-480	10,90	74	44

Überdruck / Pressure

Unterdruck / Vacuum

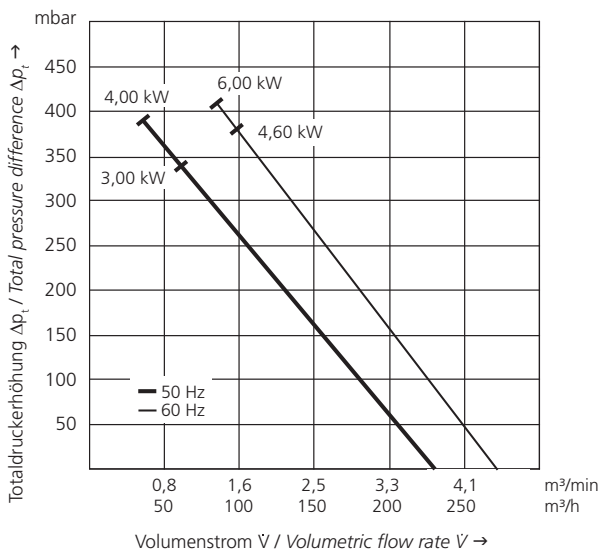
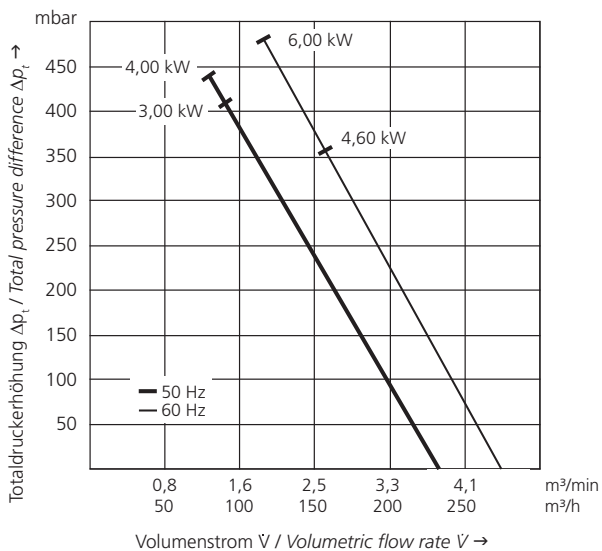

2SD 520
IE3

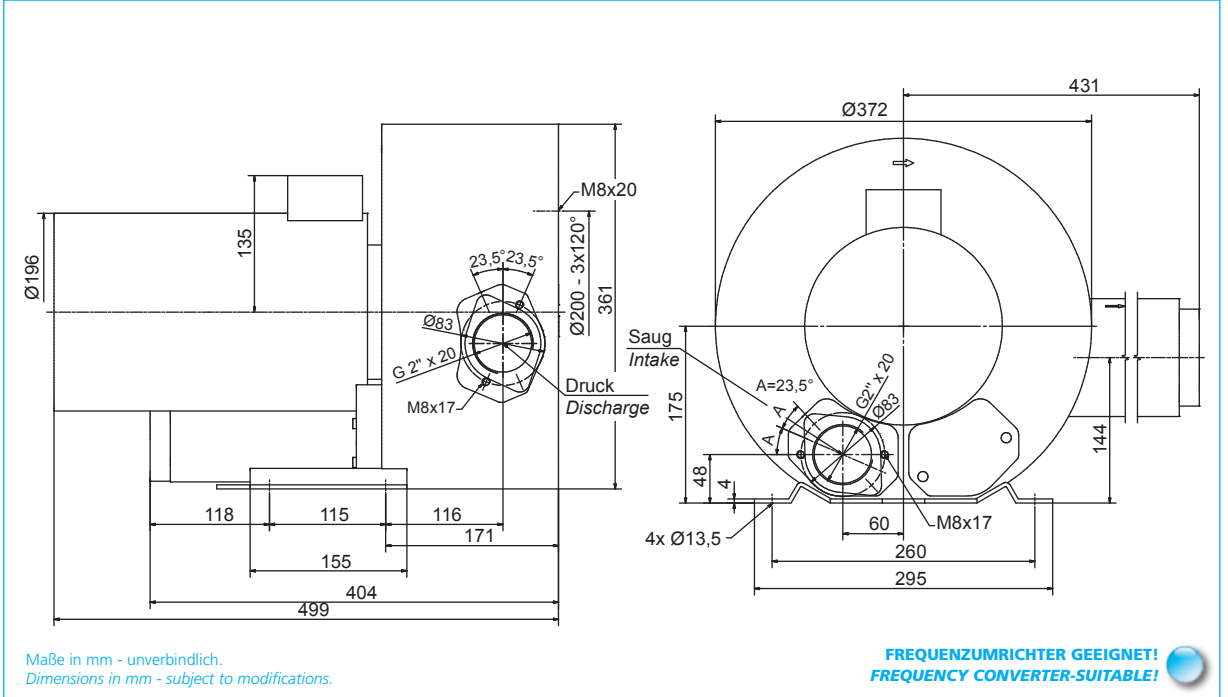

Typ Type	Effizienzklasse Efficiency class	Frequenz Frequency	Grenzwerte der Drosselkurve Überdruck Maximum performance when used as blower		Grenzwerte der Drosselkurve Unterdruck Maximum performance when used as extractor		Nennwerte des Motors Motor ratings			Schalldruckpegel Sound pressure level	Gewicht (ca.) Weight (approx.)
			\dot{V} max. \dot{V} max.	Δp_t max. Δp_t max.	\dot{V} max. \dot{V} max.	Δp_t max. Δp_t max.	Leistung Rated output	Spannung Voltage	Strom Current		
		Hz	m ³ /min	mbar	m ³ /min	mbar	kW	V	A	dB (A)	kg
2SD 520	IE3	50	3,83	450	3,83	380	3,00	230/400	9,90/5,70	72	53
		60	4,58	410	4,58	410	3,46	480	5,40	74	53

Überdruck / Pressure

Unterdruck / Vacuum

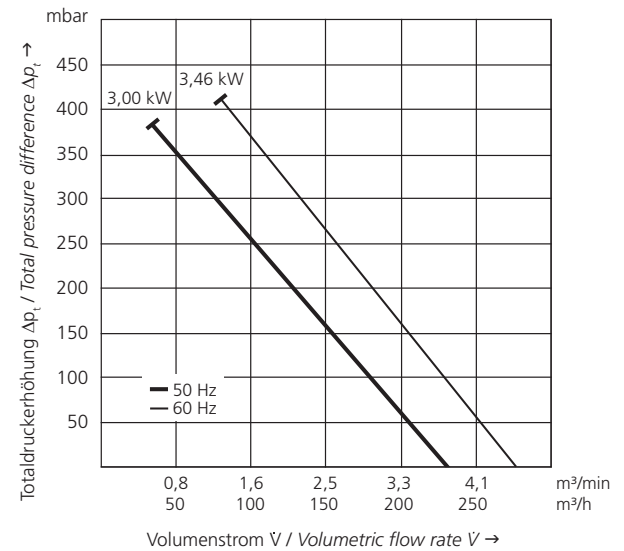
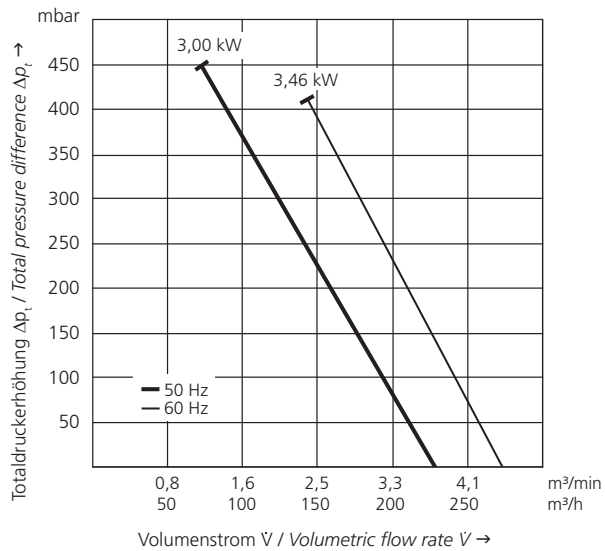

2SD 720

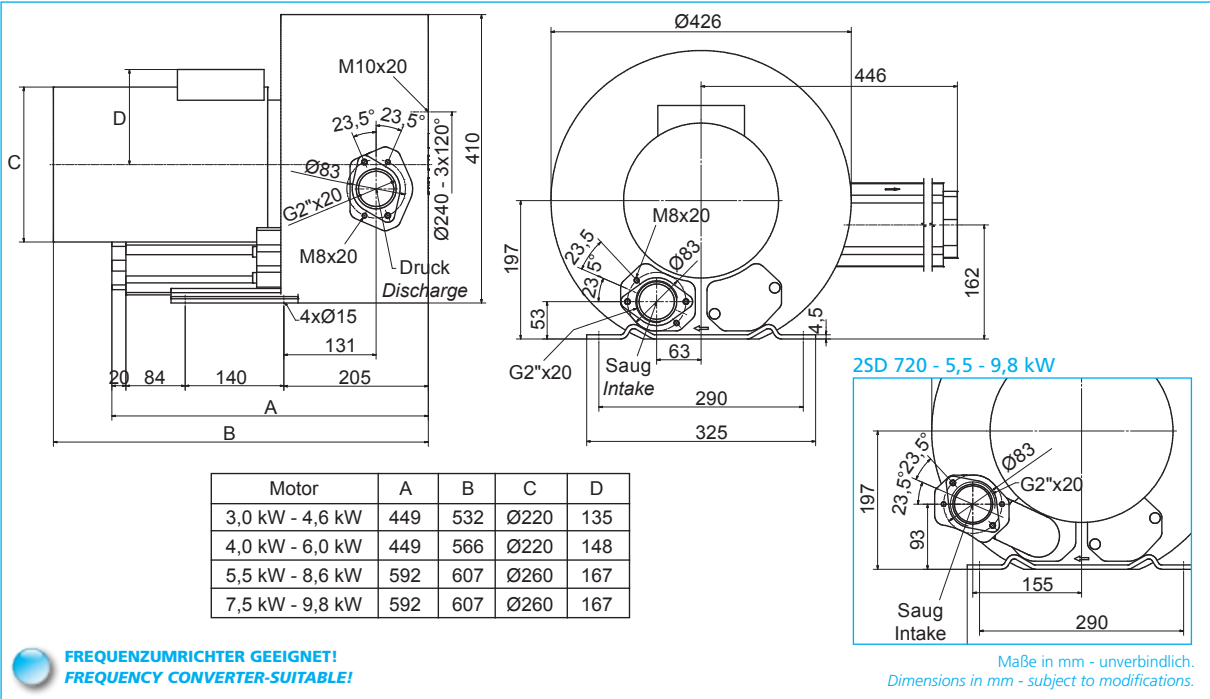

FREQUENZUMRICHTER GEEIGNET!
FREQUENCY CONVERTER-SUITABLE!

Typ	Type	Frequenz Frequency	Grenzwerte der Drosselkurve Überdruck Maximum performance when used as blower		Grenzwerte der Drosselkurve Unterdruck Maximum performance when used as extractor		Nennwerte des Motors Motor ratings			Schalldruckpegel Sound pressure level	Gewicht (ca.) Weight (approx.)
			\dot{V} max. \dot{V} max.	Δp_t max. Δp_t max.	\dot{V} max. \dot{V} max.	Δp_t max. Δp_t max.	Leistung Rated output	Spannung Voltage	Strom Current		
		Hz	m ³ /min	mbar	m ³ /min	mbar	kW	V	A	dB (A)	kg
2SD 720	✓	50	5,33	260	5,33	280	3,00	230/400	12,50/7,20	73	48
		60	6,42	200	6,42	230	4,60	277/480	14,70/8,50	76	48
2SD 720	✓	50	5,33	380	5,33	360	4,00	360-440	9,00	73	54
		60	6,42	320	6,42	350	6,00	415-480	10,90	76	54
2SD 720	✓	50	5,33	500	5,33	440	5,50	360-440	13,30	73	66
		60	6,42	500	6,42	440	8,60	415-480	15,30	76	66
2SD 720	✓	50	5,33	610	5,33	440	7,50	360-440	16,70	73	77
		60	6,42	660	6,42	460	9,80	415-480	18,20	76	77

Überdruck / Pressure

Unterdruck / Vacuum

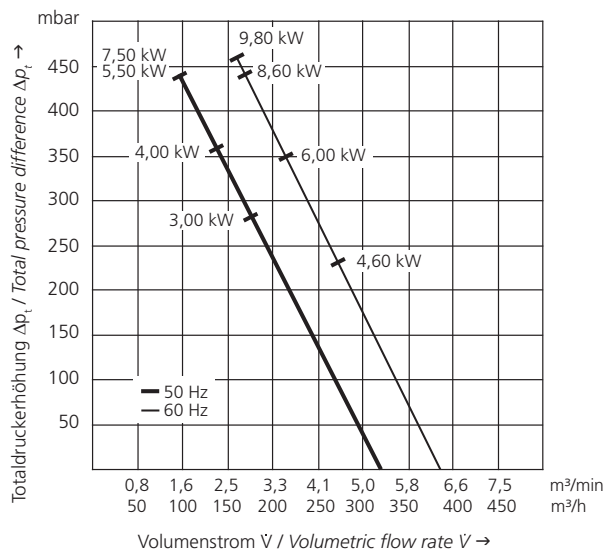
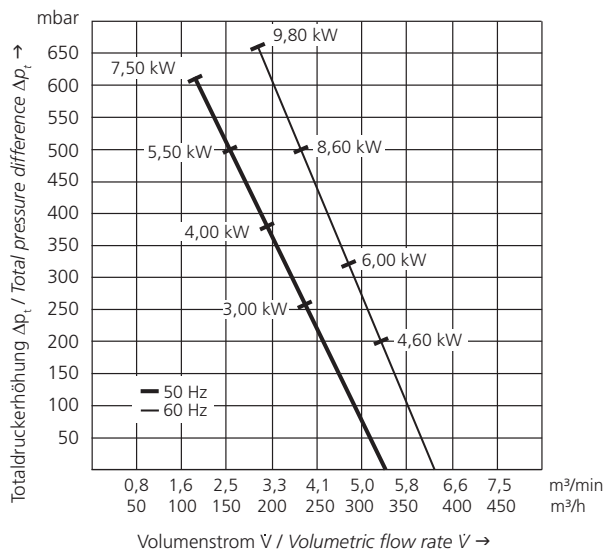

2SD 720 IE3



Motor	A	B	C	D
4,0 kW - 4,6 kW	449	566	Ø220	148
5,5 kW - 6,3 kW	592	607	Ø260	167
7,5 kW - 8,6 kW	592	607	Ø260	167

Maße in mm - unverbindlich.
Dimensions in mm - subject to modifications.

**FREQUENZUMRICHTER GEEIGNET!
FREQUENCY CONVERTER-SUITABLE!**

Typ Type	Effizienzklasse Efficiency class	Frequenz Frequency	Grenzwerte der Drosselkurve Überdruck Maximum performance when used as blower		Grenzwerte der Drosselkurve Unterdruck Maximum performance when used as extractor		Nennwerte des Motors Motor ratings			Schalldruckpegel Sound pressure level	Gewicht (ca.) Weight (approx.)
			\dot{V} max. \dot{V} max.	Δp_t max. Δp_t max.	\dot{V} max. \dot{V} max.	Δp_t max. Δp_t max.	Leistung Rated output	Spannung Voltage	Strom Current		
		Hz	m ³ /min	mbar	m ³ /min	mbar	kW	V	A	dB (A)	kg
2SD 720	IE3	50	5,33	370	5,33	400	4,00	400/690	7,45/4,30	73	67
		60	6,42	320	6,42	350	4,60	480	7,40	76	67
2SD 720	IE3	50	5,33	530	5,33	420	5,50	400/690	10,10/5,83	73	82
		60	6,42	490	6,42	440	6,30	480	9,60	76	82
2SD 720	IE3	50	5,33	610	5,33	420	7,50	400/690	13,50/7,80	73	88
		60	6,42	670	6,42	440	8,60	480	12,90	76	88

Überdruck / Pressure

Unterdruck / Vacuum

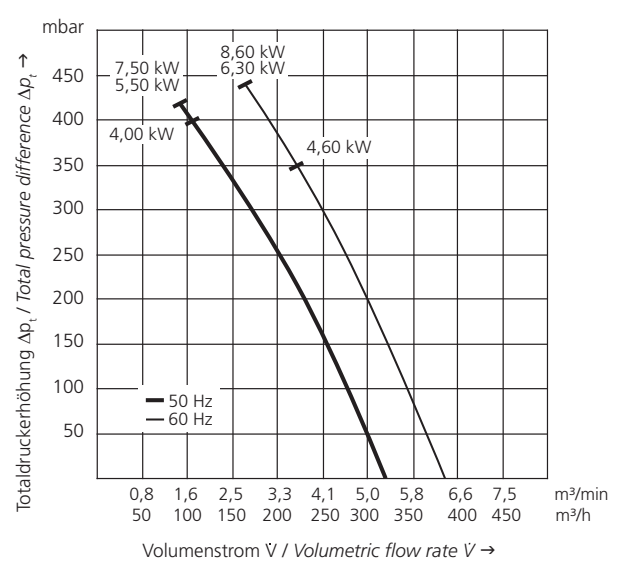
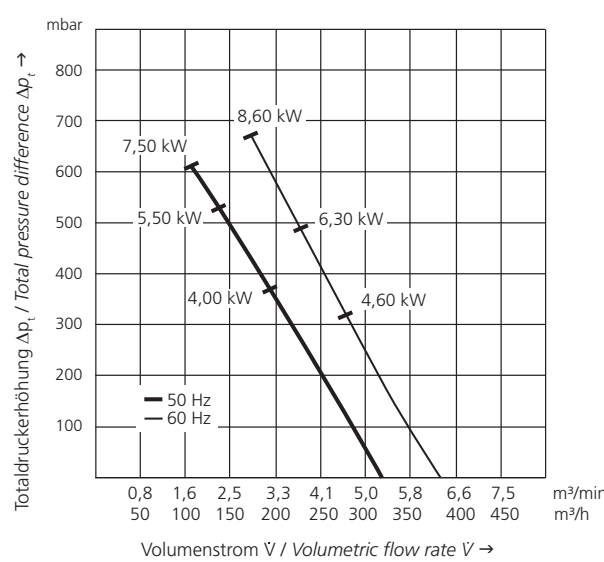

2SD 820

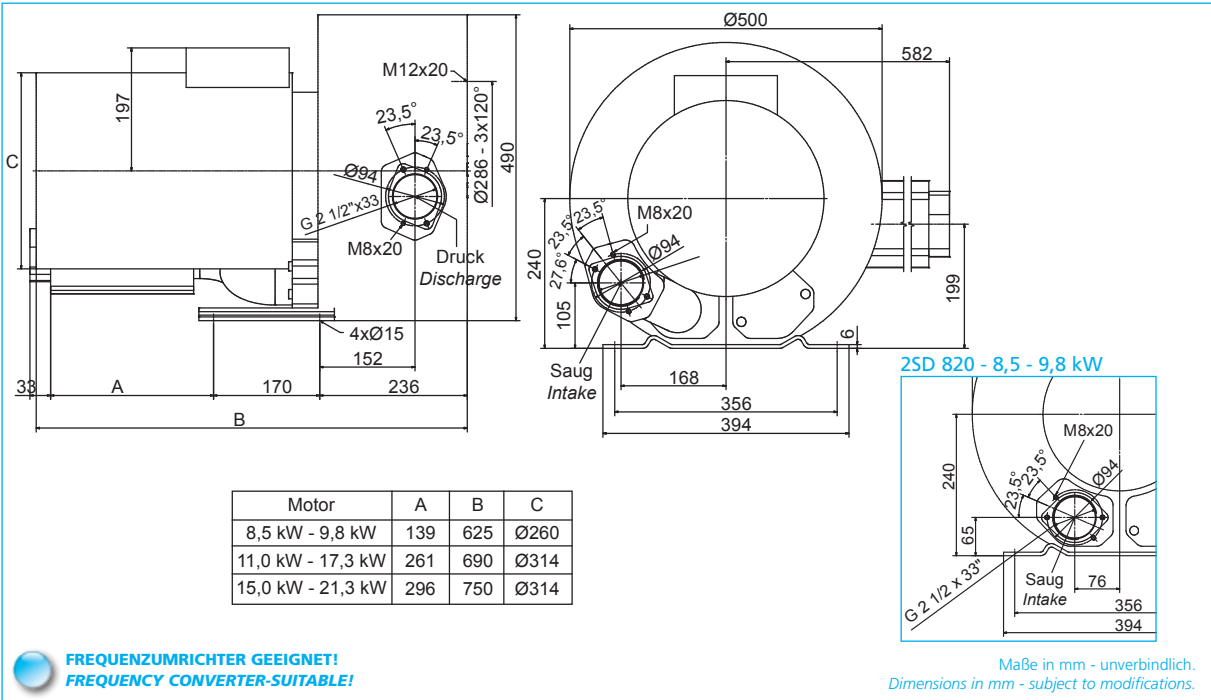

FREQUENZUMRICHTER GEEIGNET!
FREQUENCY CONVERTER-SUITABLE!

Typ Type	✓	Frequenz Frequency	Grenzwerte der Drosselkurve Überdruck Maximum performance when used as blower		Grenzwerte der Drosselkurve Unterdruck Maximum performance when used as extractor		Nennwerte des Motors Motor ratings			Schalldruckpegel Sound pressure level	Gewicht (ca.) Weight (approx.)
			\dot{V} max. \dot{V} max.	Δp_t max. Δp_t max.	\dot{V} max. \dot{V} max.	Δp_t max. Δp_t max.	Leistung Rated output	Spannung Voltage	Strom Current		
		Hz	m ³ /min	mbar	m ³ /min	mbar	kW	V	A	dB (A)	kg
2SD 820	✓	50	8,67	400	8,67	400	8,50	360-440	18,20	74	86
		60	10,33	330	10,33	360	9,80	415-480	18,20	78	86
2SD 820	✓	50	8,67	600	8,67	430	11,00	360-440	19,90	74	104
		60	10,33	600	10,33	460	17,30	415-480	33,50	78	104
2SD 820	✓	50	8,67	670	8,67	460	15,00	360-440	30,50	74	120
		60	10,33	750	10,33	490	21,30	415-480	36,50	78	120

Überdruck / Pressure

Unterdruck / Vacuum

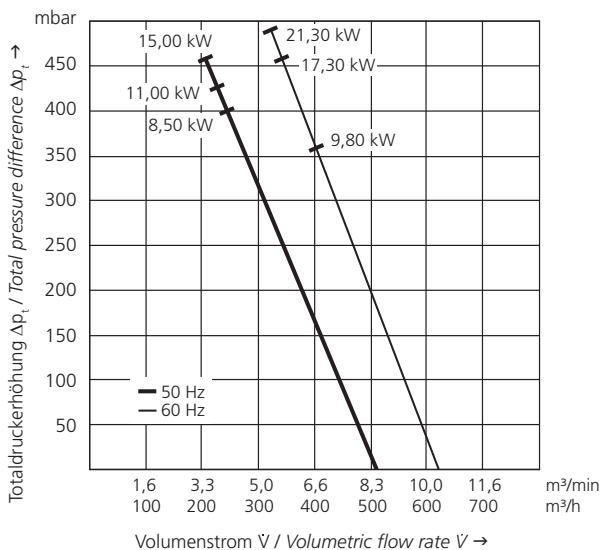
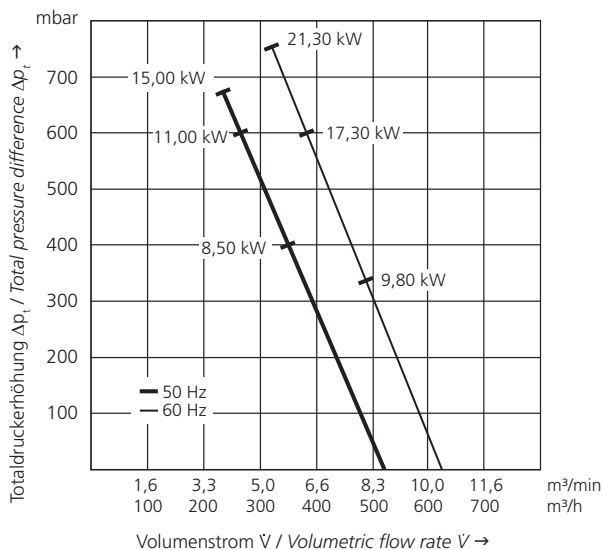

2SD 820
IE3

Motor	A	B	C
7,5 kW - 8,6 kW	139	625	Ø260
11,0 kW - 12,6 kW	261	690	Ø314
15,0 kW - 17,3 kW	296	750	Ø314

Maße in mm - unverbindlich.
Dimensions in mm - subject to modifications.

FREQUENZUMRICHTER GEEIGNET!
FREQUENCY CONVERTER-SUITABLE!

Typ Type	Effizienzklasse Efficiency class	Frequenz Frequency	Grenzwerte der Drosselkurve Überdruck Maximum performance when used as blower		Grenzwerte der Drosselkurve Unterdruck Maximum performance when used as extractor		Nennwerte des Motors Motor ratings			Schalldruckpegel Sound pressure level	Gewicht (ca.) Weight (approx.)
			\dot{V} max. \dot{V} max.	Δp_t max. Δp_t max.	\dot{V} max. \dot{V} max.	Δp_t max. Δp_t max.	Leistung Rated output	Spannung Voltage	Strom Current		
		Hz	m ³ /min	mbar	m ³ /min	mbar	kW	V	A	dB (A)	kg
2SD 820	IE3	50	8,67	360	8,67	380	7,50	400/690	13,30/7,68	74	103
		60	10,33	320	10,33	330	8,60	480	13,30	78	103
2SD 820	IE3	50	8,67	570	8,67	460	11,00	400/690	19,60/11,30	74	135
		60	10,33	540	10,33	460	12,60	480	18,70	78	135
2SD 820	IE3	50	8,67	800	8,67	480	15,00	400/690	26,50/15,30	74	146
		60	10,33	720	10,33	460	17,30	480	26,00	78	146

Überdruck / Pressure

Unterdruck / Vacuum

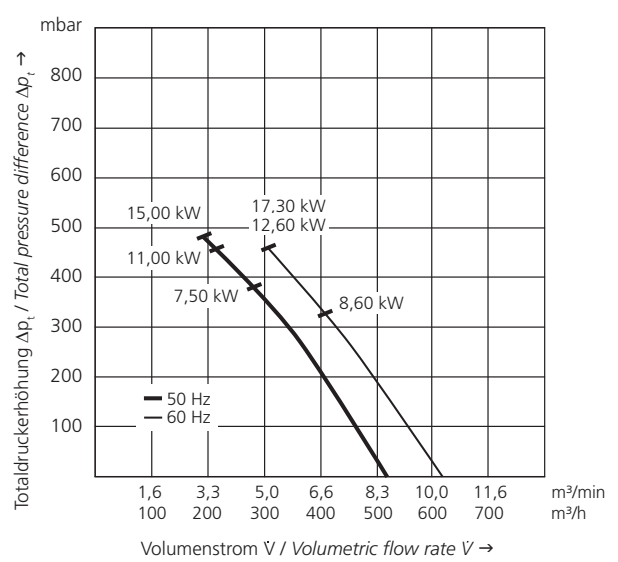
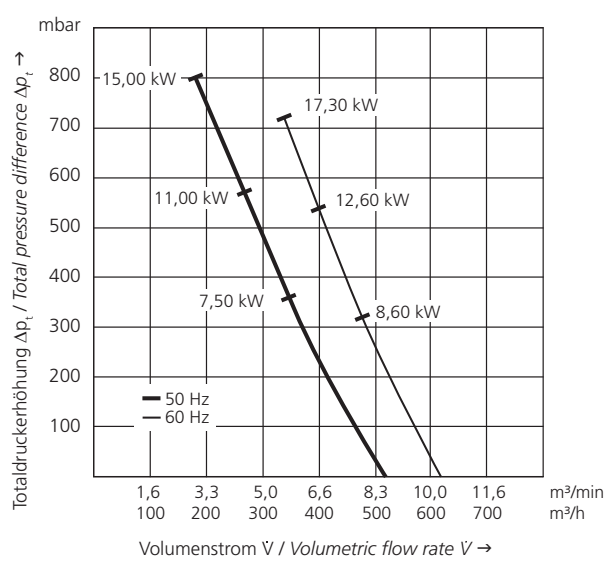

2SD 920

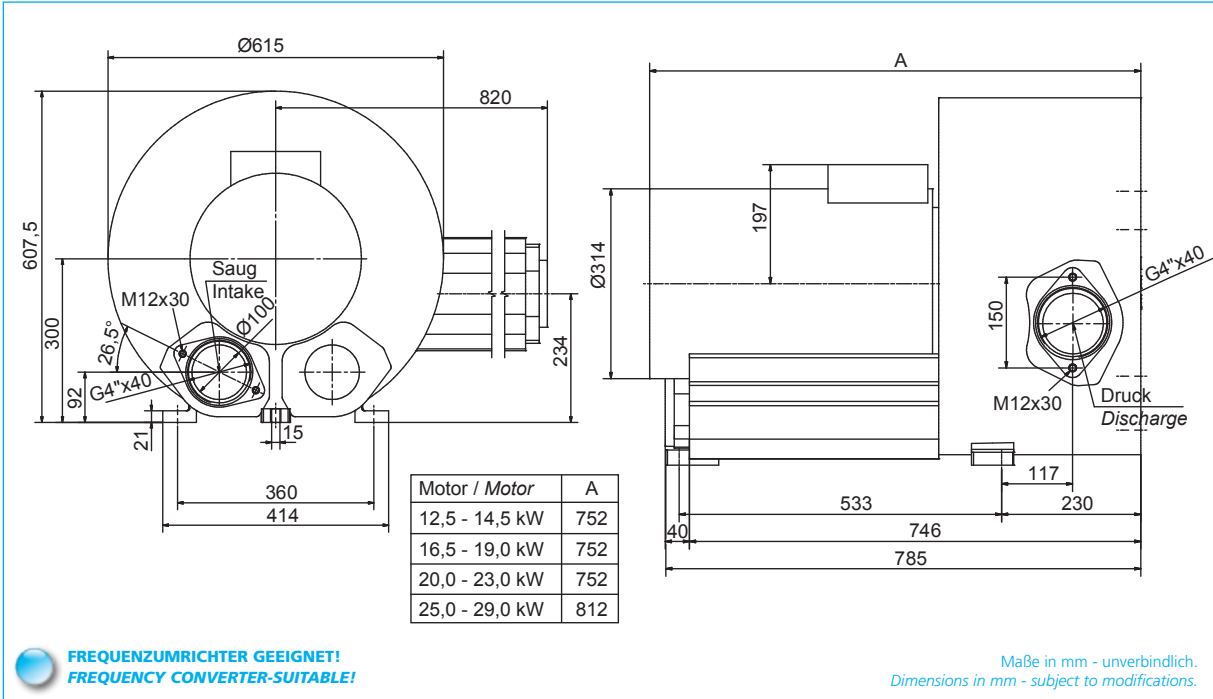

FREQUENZUMRICHTER GEEIGNET!
FREQUENCY CONVERTER-SUITABLE!

Maße in mm - unverbindlich.
Dimensions in mm - subject to modifications.

Typ	Type	Frequenz Frequency	Grenzwerte der Drosselkurve Überdruck Maximum performance when used as blower		Grenzwerte der Drosselkurve Unterdruck Maximum performance when used as extractor		Nennwerte des Motors Motor ratings			Schalldruckpegel Sound pressure level	Gewicht (ca.) Weight (approx.)
			\dot{V} max. \dot{V} max.	Δp_t max. Δp_t max.	\dot{V} max. \dot{V} max.	Δp_t max. Δp_t max.	Leistung Rated output	Spannung Voltage	Strom Current		
		Hz	m ³ /min	mbar	m ³ /min	mbar	kW	V	A	dB (A)	kg
2SD 920	✓	50	18,50	270	18,50	300	12,50	360-440	28,00	74	187
		60	21,83	200	21,83	220	14,50	415-480	26,00	78	187
2SD 920	✓	50	18,50	370	18,50	410	16,50	360-440	35,00	74	197
		60	21,83	300	21,83	340	17,30	415-480	33,50	78	197
2SD 920	✓	50	18,50	500	18,50	440	20,00	360-440	40,00	74	204
		60	21,83	430	21,83	440	23,00	415-480	39,50	78	204
2SD 920	✓	50	18,50	590	18,50	440	25,00	360-440	52,00	74	211
		60	21,83	540	21,83	440	29,00	415-480	48,00	78	211

Überdruck / Pressure

Unterdruck / Vacuum

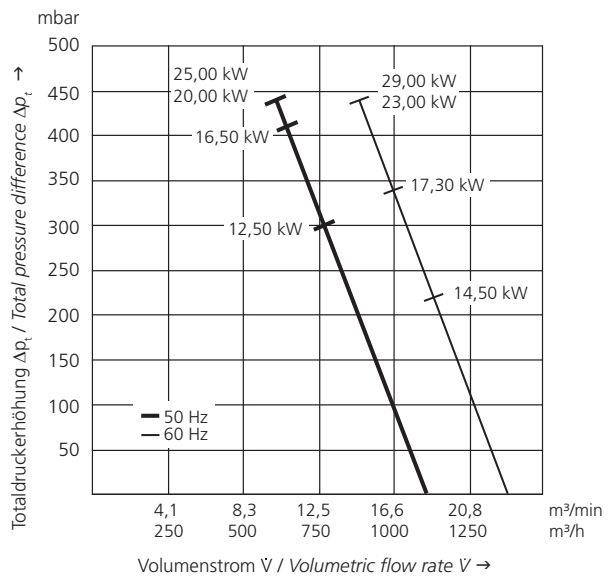
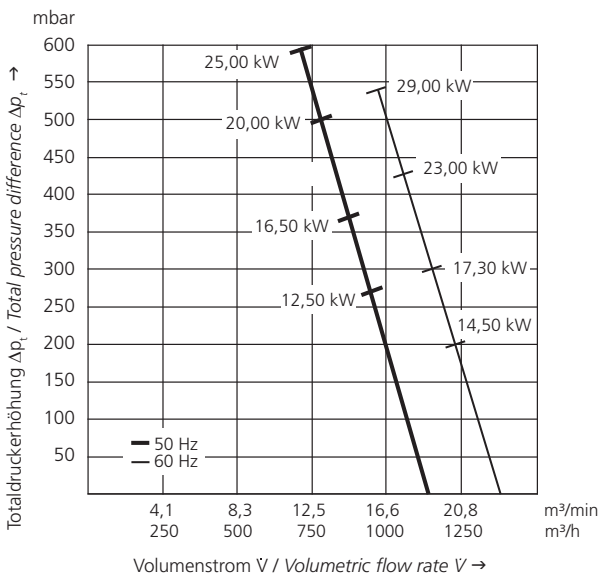

**2SD 920
IE3**

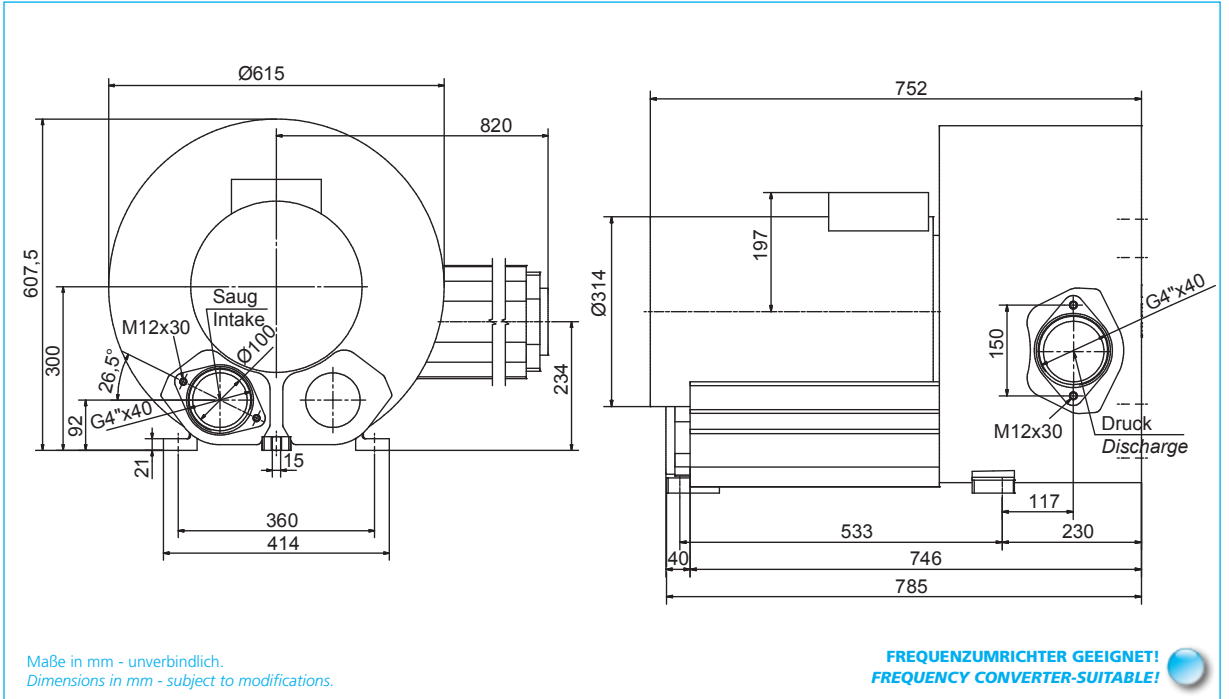

Typ Type	Effizienzklasse Efficiency class	Frequenz Frequency	Grenzwerte der Drosselkurve Überdruck Maximum performance when used as blower		Grenzwerte der Drosselkurve Unterdruck Maximum performance when used as extractor		Nennwerte des Motors Motor ratings			Schalldruckpegel Sound pressure level	Gewicht (ca.) Weight (approx.)
			\dot{V} max. \dot{V} max.	Δp_t max. Δp_t max.	\dot{V} max. \dot{V} max.	Δp_t max. Δp_t max.	Leistung Rated output	Spannung Voltage	Strom Current		
		Hz	m ³ /min	mbar	m ³ /min	mbar	kW	V	A	dB (A)	kg
2SD 920	IE3	50	18,50	250	18,50	270	11,00	400/690	19,60/11,30	74	195
		60	21,83	190	21,83	220	12,60	480	18,70	78	195
2SD 920	IE3	50	18,50	370	18,50	410	15,00	400/690	26,50/15,30	74	208
		60	21,83	320	21,83	390	17,30	480	26,00	78	208
2SD 920	IE3	50	18,50	490	18,50	440	18,50	400/690	32,50/18,80	74	210
		60	21,83	430	21,83	460	21,30	480	32,40	78	210

Überdruck / Pressure

Unterdruck / Vacuum

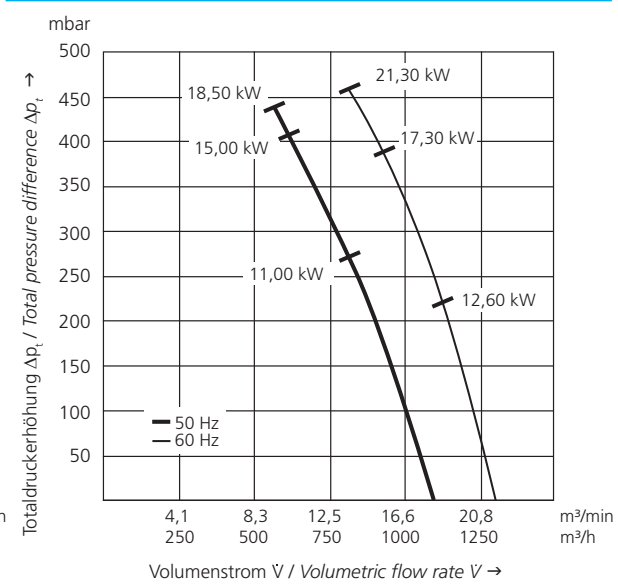
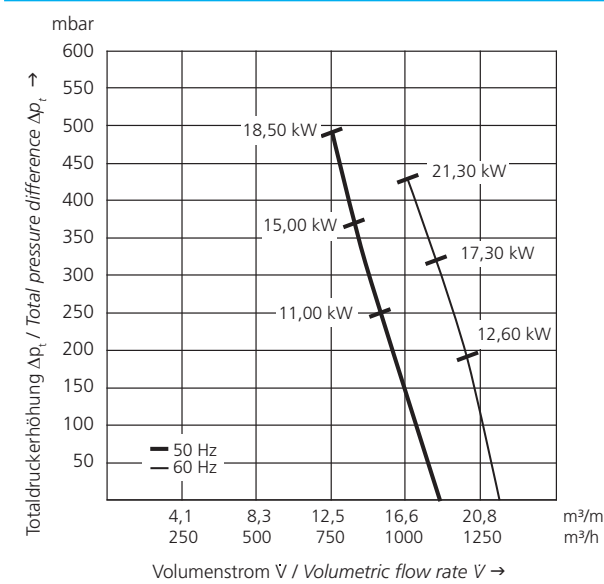

2SD 740

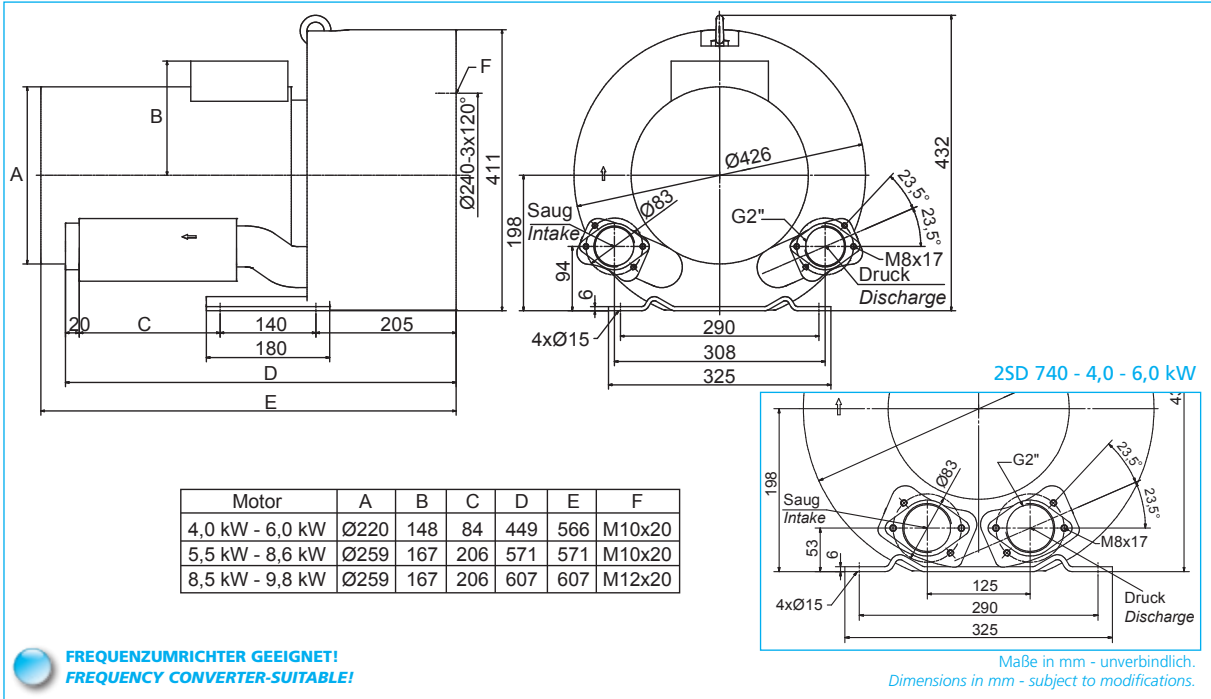

FREQUENZUMRICHTER GEEIGNET!
FREQUENCY CONVERTER-SUITABLE!

Typ	Type	Frequenz Frequency	Grenzwerte der Drosselkurve Überdruck		Grenzwerte der Drosselkurve Unterdruck		Nennwerte des Motors			Schalldruckpegel Sound pressure level	Gewicht (ca.) Weight (approx.)
			\dot{V} max.	Δp_t max.	\dot{V} max.	Δp_t max.	Leistung	Spannung	Strom		
		Hz	m ³ /min	mbar	m ³ /min	mbar	kW	V	A	dB (A)	kg
2SD 740	✓	50	8,83	140	8,83	150	4,00	360-440	7,80	74	54
		60	10,00	90	10,00	100	6,00	415-480	9,00	78	54
2SD 740	✓	50	8,83	260	8,83	200	5,50	360-440	10,50	74	69
		60	10,00	200	10,00	210	8,60	415-480	10,30	78	69

Überdruck / Pressure

Unterdruck / Vacuum

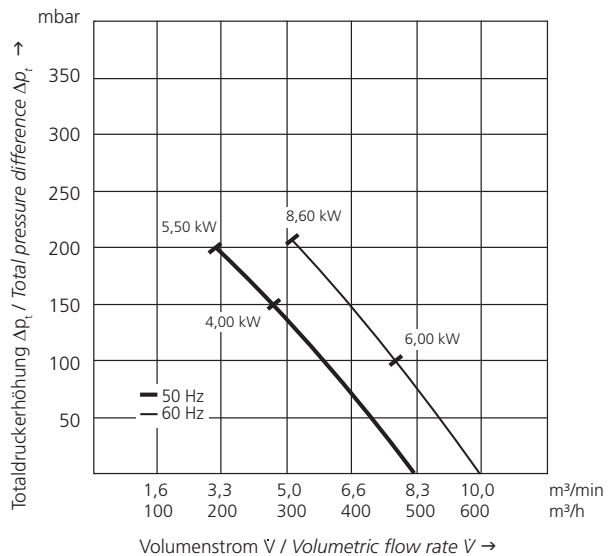
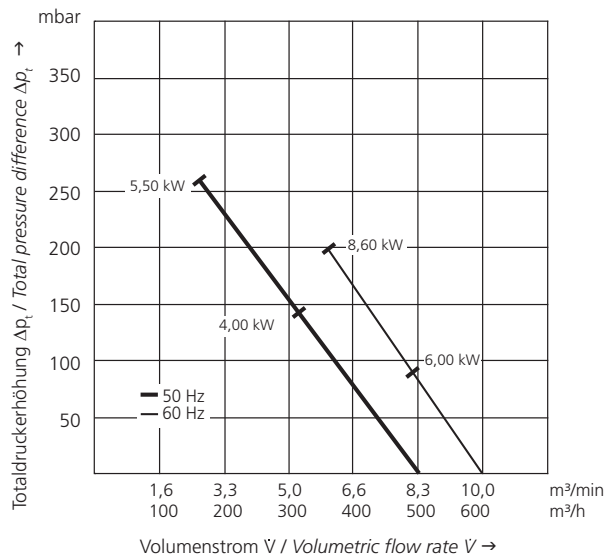

2SD 840



2SD 840 - 11,0 - 17,3 kW

Motor	A	B	C	D	E	F
8,5 - 9,8 kW	167	Ø260	183	589	622	236
11,0 - 17,3 kW	197	Ø314	312	694	727	212

Maße in mm - unverbindlich.
Dimensions in mm - subject to modifications.

FREQUENZUMRICHTER GEEIGNET!
FREQUENCY CONVERTER-SUITABLE!

Typ Type	✓	Frequenz Frequency	Grenzwerte der Drosselkurve Überdruck Maximum performance when used as blower		Grenzwerte der Drosselkurve Unterdruck Maximum performance when used as extractor		Nennwerte des Motors Motor ratings			Schalldruckpegel Sound pressure level	Gewicht (ca.) Weight (approx.)
			\dot{V} max. \dot{V} max.	Δp_t max. Δp_t max.	\dot{V} max. \dot{V} max.	Δp_t max. Δp_t max.	Leistung Rated output	Spannung Voltage	Strom Current		
		Hz	m ³ /min	mbar	m ³ /min	mbar	kW	V	A	dB (A)	kg
2SD 840	✓	50	15,00	180	15,00	200	8,50	360-440	18,20	74	91
		60	17,50	120	17,50	150	9,80	415-480	18,20	78	91
2SD 840	✓	50	15,00	370	15,00	280	11,00	360-440	19,90	74	110
		60	17,50	350	17,50	310	17,30	415-480	33,50	78	110

Überdruck / Pressure

Unterdruck / Vacuum

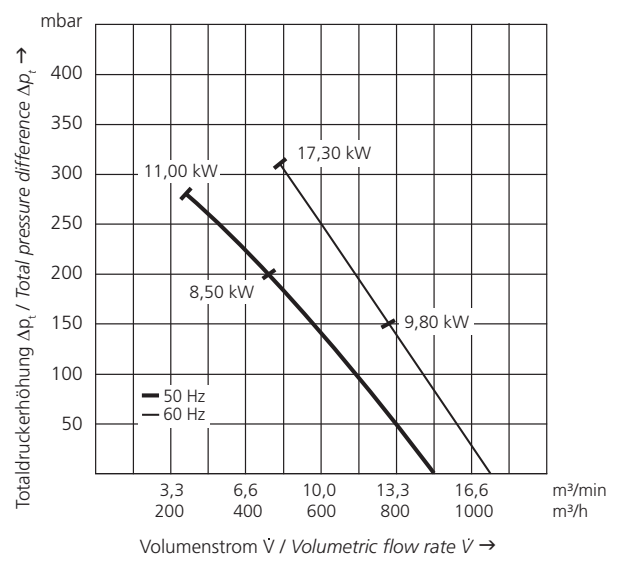
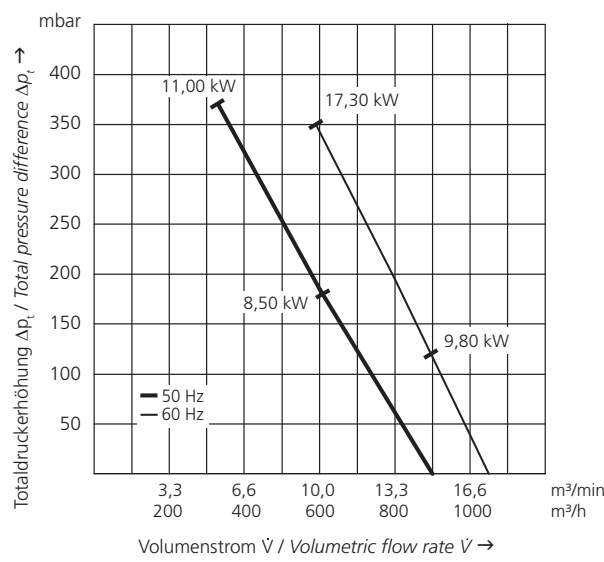

**2SD 840
IE3**



2SD 840 - 11,0 - 12,6 kW

Motor	A	B	C	D	E	F
7,5 - 8,6 kW	167	Ø260	183	589	622	236
11,0 - 12,6 kW	197	Ø314	312	694	727	212

FREQUENZUMRICHTER GEEIGNET!
FREQUENCY CONVERTER-SUITABLE!

Maße in mm - unverbindlich.
Dimensions in mm - subject to modifications.

Typ Type	Effizienzklasse Efficiency class	Frequenz Frequency	Grenzwerte der Drosselkurve Überdruck Maximum performance when used as blower		Grenzwerte der Drosselkurve Unterdruck Maximum performance when used as extractor		Nennwerte des Motors Motor ratings			Schalldruckpegel Sound pressure level	Gewicht (ca.) Weight (approx.)
			\dot{V}_{max} \dot{V}_{max}	$\Delta p_t max.$ $\Delta p_t max.$	\dot{V}_{max} \dot{V}_{max}	$\Delta p_t max.$ $\Delta p_t max.$	Leistung Rated output	Spannung Voltage	Strom Current		
		Hz	m ³ /min	mbar	m ³ /min	mbar	kW	V	A	dB (A)	kg
2SD 840	IE3	50	15,00	180	15,00	160	7,50	400/690	13,30/7,68	74	105
		60	17,50	120	17,50	120	8,60	480	13,30	78	105
2SD 840	IE3	50	15,00	290	15,00	260	11,00	400/690	19,60/11,30	74	137
		60	17,50	240	17,50	220	12,60	480	18,70	78	137

Überdruck / Pressure

Unterdruck / Vacuum

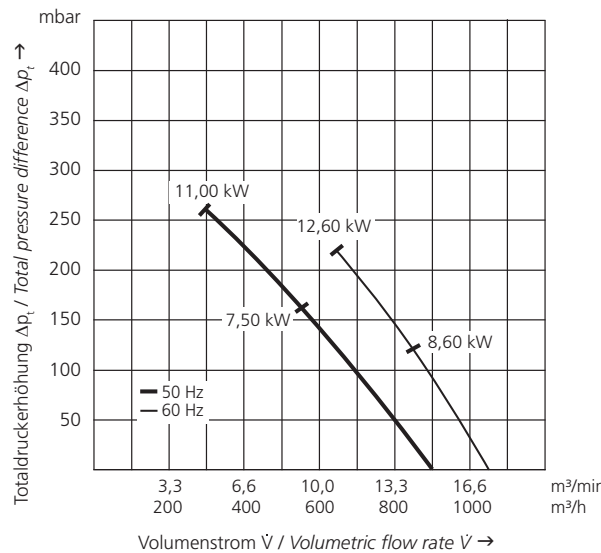
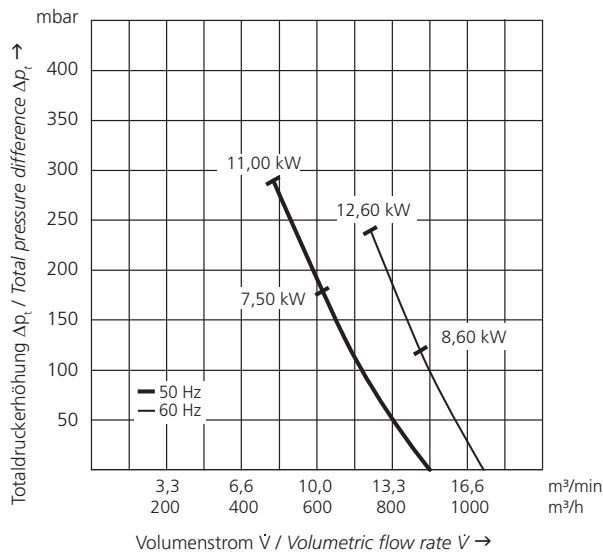



TECHNISCHE HINWEISE FREQUENZUMRICHTER TECHNICAL INFORMATION FREQUENCY CONVERTER

Omron Frequenzumrichter (FU) für den abgesetzten Betrieb von 50 Hz-Geräten
Omron frequency converter for the off-set operation of 50 Hz-devices

Omron MX2
(Grenzwertklasse C2)
230 V Klasse

Omron MX2
(Limiting value class C2)
230 V class

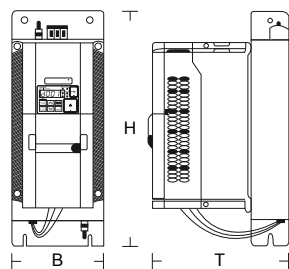

Leistung <i>Rated Power</i>	für Gerät <i>for device</i>	Abmessungen (B x H x T) <i>Dimensions (B x H x T)</i>	Gewicht <i>Weight</i>	FU-Paket* Artikel-Nr. <i>FU-package* Article No.</i>
kW		mm	kg	
0,37	1SD 210 - 50/0,37	71 x 169 x 168	1,70	9016660
0,75	1SD 310 - 50/0,75 1SD 410 - 50/0,75 2SD 220 - 50/0,55	111 x 169 x 221	2,20	9016662
1,50	1SD 310 - 50/1,10 1SD 410 - 50/1,10 1SD 510 - 50/1,10 2SD 320 - 50/1,10	111 x 169 x 221	2,60	9016664
2,20	1SD 510 - 50/1,50 (IE3) 1SD 510 - 50/1,60 1SD 510 - 50/2,20 1SD 510 - 50/2,20 (IE3) 1SD 710 - 50/2,20 1SD 710 - 50/2,20 (IE3) 2SD 420 - 50/1,50 (IE3) 2SD 420 - 50/1,60 2SD 420 - 50/2,20 2SD 420 - 50/2,20 (IE3)	111 x 169 x 221	2,60	9016666

* FU-Paket besteht aus Frequenzumrichter und passendem EMV-Unterbaufilter.
* *FU-package consist of frequency converter and suitable EMC foot-print filter.*

Omron MX2
(Grenzwertklasse C2)
400 V Klasse

Omron MX2
(Limiting value class C2)
400 V class

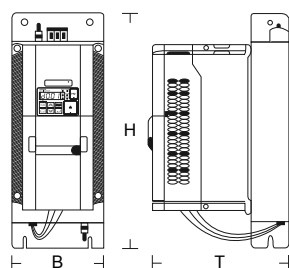

Leistung <i>Rated Power</i>	für Gerät <i>for device</i>	Abmessungen (B x H x T) <i>Dimensions (B x H x T)</i>	Gewicht <i>Weight</i>	FU-Paket* Artikel-Nr. <i>FU-package* Article No.</i>
kW		mm	kg	
0,75	1SD 310 - 50/0,75 1SD 410 - 50/0,75 1SD 410 - 50/0,75 (IE3) 2SD 220 - 50/0,55	114 x 169 x 190	2,60	9016667
1,50	1SD 310 - 50/1,10 1SD 410 - 50/1,10 1SD 410 - 50/1,10 (IE3) 1SD 510 - 50/1,10 1SD 510 - 50/1,10 (IE3) 2SD 320 - 50/1,10	114 x 169 x 217	2,80	9016669
2,20	1SD 510 - 50/1,50 (IE3) 1SD 510 - 50/1,60 1SD 510 - 50/2,20 1SD 510 - 50/2,20 (IE3) 1SD 710 - 50/2,20 1SD 710 - 50/2,20 (IE3) 2SD 420 - 50/1,50 (IE3) 2SD 420 - 50/1,60 2SD 420 - 50/2,20 2SD 420 - 50/2,20 (IE3)	114 x 169 x 217	2,90	9016671
3,00	1SD 710 - 50/3,00 1SD 710 - 50/3,00 (IE3) 2SD 520 - 50/3,00 2SD 520 - 50/3,00 (IE3) 2SD 720 - 50/3,00	114 x 169 x 217	2,90	9016672
4,00	1SD 510 - 80/3,80 1SD 710 - 50/4,00 1SD 710 - 50/4,00 (IE3)	114 x 174 x 221	3,20	9016673

Maße in mm - unverbindlich. Änderungen vorbehalten.
Dimensions in mm - without obligation. Subject to modification.



TECHNISCHE HINWEISE FREQUENZUMRICHTER TECHNICAL INFORMATION FREQUENCY CONVERTER

Leistung Rated Power	für Gerät for device	Abmessungen (B x H x T) Dimensions (B x H x T)	Gewicht Weight	FU-Paket* Artikel-Nr. FU-package* Article No.
kW		mm	kg	
4,00	1SD 810 - 50/4,00 1SD 810 - 50/4,00 ^(IE3) 2SD 520 - 50/4,00 2SD 720 - 50/4,00 2SD 720 - 50/4,00 ^(IE3) 2SD 740 - 50/4,00	114 x 174 x 221	3,20	9016673
5,50	1SD 810 - 50/5,50 1SD 810 - 50/5,50 ^(IE3) 2SD 720 - 50/5,50 2SD 720 - 50/5,50 ^(IE3) 2SD 740 - 50/5,50	150 x 306 x 207	5,50	9016675
7,50	1SD 810 - 50/7,50 1SD 810 - 50/7,50 ^(IE3) 1SD 910 - 50/7,50 ^(IE3) 2SD 720 - 50/7,50 2SD 720 - 50/7,50 ^(IE3) 2SD 820 - 50/7,50 ^(IE3) 2SD 840 - 50/7,50 ^(IE3)	150 x 306 x 207	5,50	9016677
11,00	1SD 910 - 50/8,50 1SD 910 - 50/11,00 ^(IE3) 2SD 820 - 50/8,50 2SD 820 - 50/11,00 2SD 820 - 50/11,00 ^(IE3) 2SD 920 - 50/11,00 ^(IE3) 2SD 840 - 50/8,50 2SD 840 - 50/11,00 2SD 840 - 50/11,00 ^(IE3)	182 x 357 x 237	7,50	9016678
15,00	1SD 910 - 50/12,50 2SD 820 - 50/15,00 2SD 820 - 50/15,00 ^(IE3) 2SD 920 - 50/12,50 2SD 920 - 50/15,00 ^(IE3)	182 x 357 x 237	8,00	9016680

* FU-Paket besteht aus Frequenzumrichter und passendem EMV-Unterbaufilter.
* FU-package consist of frequency converter and suitable EMC foot-print filter.

Omron RX
(Grenzwertklasse C2)
400 V Klasse

Omron RX
(Limiting value class C2)
400 V class

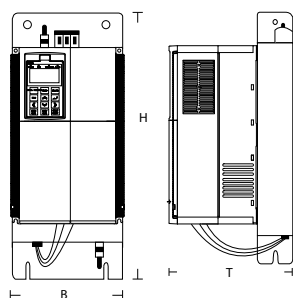

Leistung Rated Power	für Gerät for device	Abmessungen (B x H x T) Dimensions (B x H x T)	Gewicht Weight	FU-Paket* Artikel-Nr. FU-package* Article No.
kW		mm	kg	
18,50	1SD 910 - 50/18,50 1SD 910 - 50/18,50 ^(IE3) 2SD 920 - 50/16,50 2SD 920 - 50/18,50 ^(IE3)	252 x 451 x 250	18,50	9019560
22,00	2SD 920 - 50/20,00	252 x 451 x 250	18,50	9019562
30,00	2SD 920 - 50/25,00	310 x 598 x 265	29,00	9019564

* FU-Paket besteht aus Frequenzumrichter und passendem EMV-Unterbaufilter.
* FU-package consist of frequency converter and suitable EMC foot-print filter.



TECHNISCHE HINWEISE FREQUENZUMRICHTER TECHNICAL INFORMATION FREQUENCY CONVERTER

Omron Zubehör

Omron Accessories

	Bezeichnung Denomination	Artikel-Nr. Article No.
	LCD-Zusatzbedienfeld für Omron MX2 Add-on LCD control panel for Omron MX2	9016681
	Verlängerungskabel 3m für LCD-Zusatzbedienfeld für Omron MX2 und RX Extension cable 3m for add-on LCD control panel for Omron MX2 and RX	9016682
	USB-Parametrierkabel 3m Länge für Omron MX2 USB cable for parameterization 3m length for Omron MX2	9016683
	RJ45-USB Parametrierkabel, 3 m Länge für Omron RX RJ45-USB cable for parameterization, 3m length for Omron RX	9019607
	Parametriersoftware Omron MX2 und RX Software for parameterization Omron MX2 and RX	9016684

Kostal direkt auf dem Motor aufgebaute Frequenzumrichter (FUK)

Leistungszuordnung, falls nicht anders angegeben, passend für 50 Hz-Geräte (60 Hz-Geräte auf Anfrage)

Kostal on the motor integrated frequency converter (FUK)

Performance allocation, unless otherwise indicated, suitable for 50 Hz devices (60 Hz devices upon request)

Kostal INVEOR

(EMV-Kategorie C2)

400 V Klasse

Kostal INVEOR

(EMC-category C2)

400 V class

Leistung Rated Power	für Gerät for device	Abmessungen (L x B x H) Dimensions (L x B x H)	Gewicht Weight	FU-Einheit Artikel-Nr. FU drive unit Article No.
kW		mm	kg	
4,00	1SD 510 FUK 80/3,80	270 x 189 x 140	5,00	9020747

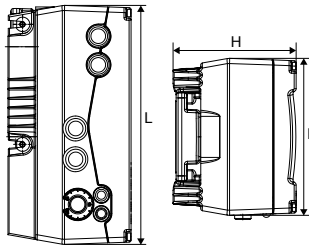

Kostal INVEOR Zubehör

Kostal INVEOR Accessories

	Bezeichnung Denomination	Artikel-Nr. Article No.
	Bedienfeld MMI INVEOR Control panel MMI INVEOR	9020758
	PC Schnittstellenkabel Interface cable for PC	9020759

HINWEIS:

Bei Arbeitsbereichen oberhalb der Begrenzungspunkte bis zur maximal zulässigen Auslastung der Seitenkanalverdichter ist eine Anpassung der Stromgrenzwerte im Frequenzumrichter und ggf. eine größere Frequenzumrichter-Bemessungsleistung erforderlich. Bitte kontaktieren Sie hierzu unser Produktmanagement (support@elektor.de).

NOTE:

In operating areas above limiting points up to maximum utilization of the side channel blowers, an adaption of the current limits in the frequency converter and respectively a larger frequency power rating is necessary. Please contact in this case our Product Management (support@elektor.com).

TECHNISCHE HINWEISE REVERSIERAUTOMATEN TECHNICAL INFORMATION REVERSING UNITS



Reversierautomaten / Reversing units

Kombination Verdichter / Reversierautomat		Spannung Voltage	Strom Current	Frequenz Frequency	Kondensator Capacitor	Umschaltzeit Switch-over time		Gewicht Weight	Artikel-Nr. Article No.
Typ / Type	Typ / Type					Reversierung Reversing	Impuls bzw. neutral impulse or neutral		
1SD 410	RAGZ 4	200-240	0,041 / 0,053	50/60	0,33 / 400 V	0,7	0,35	4,3	100621
1SD 510	RAGZ 6	200-240	0,041 / 0,053	50/60	0,33 / 400 V	0,7	0,35	5,9	100620
1SD 710	RAGZ 6	200-240	0,041 / 0,053	50/60	0,33 / 400 V	0,7	0,35	5,9	100601
1SD 810	RAGZ 8	200-240	0,10 / 0,12	50/60	0,68 / 400 V	0,7	0,35	8,7	100622

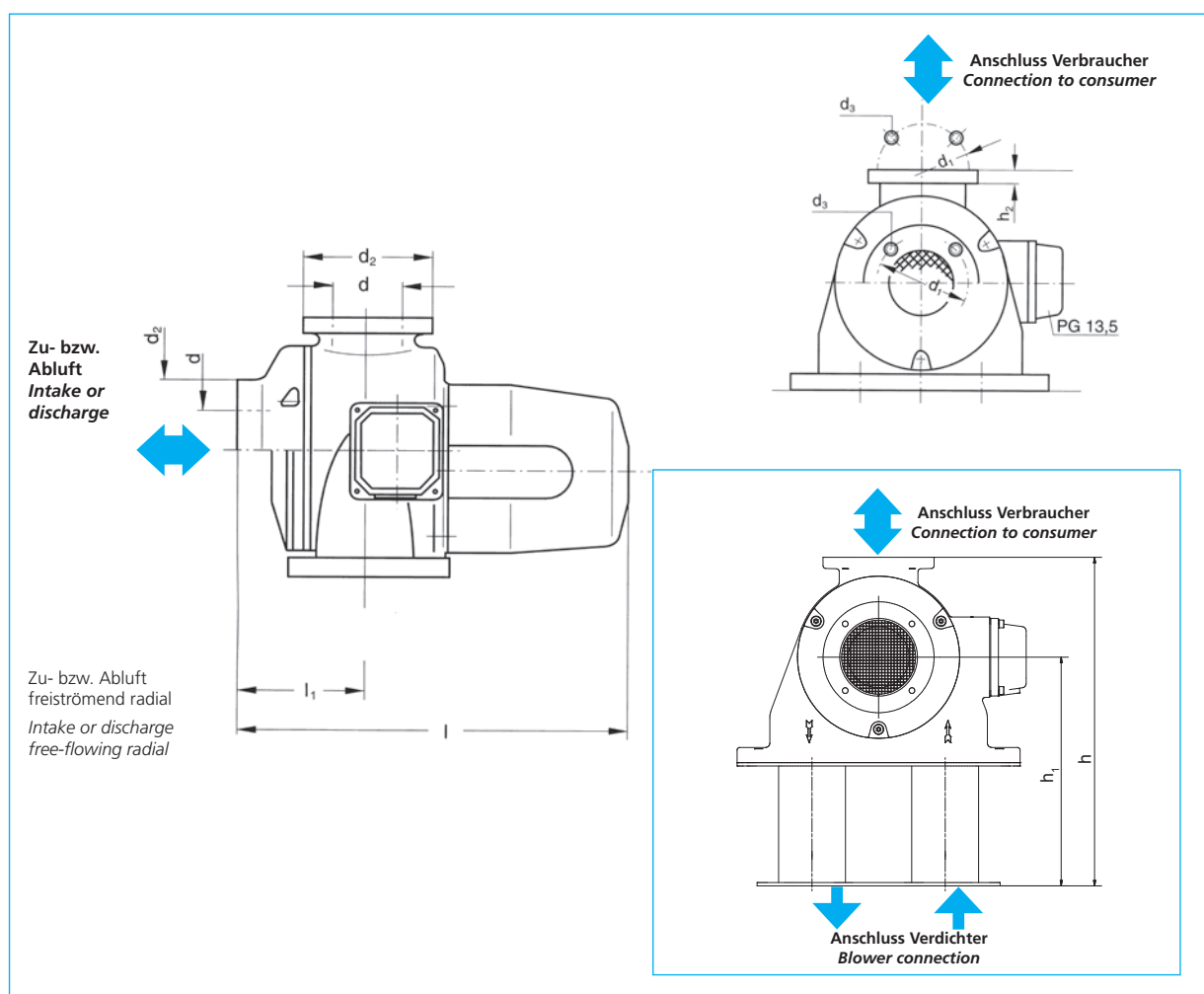

Typ Type	l	l ₁	d	d ₁	d ₂	d ₃	h	h ₁	h ₂
1SD 410 RAGZ 4	267	80	45	68	80	M5	261	181	10
1SD 510 RAGZ 6	294	95	55	85	100	M6	316	226	10
1SD 710 RAGZ 6	294	95	55	85	100	M6	406	316	10
1SD 810 RAGZ 8	372	104	65	110	130	M8	351	246	12

Technische Hinweise und Funktionsbeschreibung siehe Seite 5 und 6 (Abschnitt 1.6 Reversierautomaten)
Technical information and functional description see on page 5 and 6 (Article 1.6 Reversing units)



ZUBEHÖR 1SD/2SD ACCESSORIES 1SD/2SD

Begrenzungsventil 1SD Relief valve 1SD

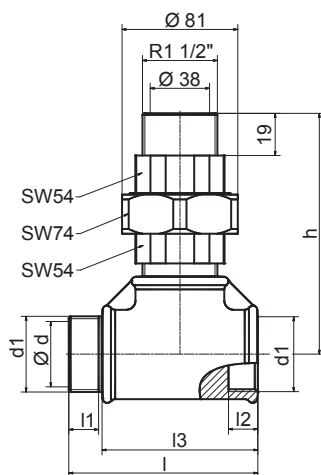

Typ Type	Betrieb/ Operation	d	d1	l	l1	l2	l3	h	Artikel-Nr. Article No.	Artikel-Nr. Article No.
									50 Hz	60 Hz
1SD 210-50/0,37	druckseitig / pressure side	36	1 1/4"	176	80	19	96	160	9020366	9020368
	saugseitig / vacuum side								9020367	9020369
1SE 210-50/0,37	druckseitig / pressure side	36	1 1/4"	176	80	19	96	160	9020366	9020368
	saugseitig / vacuum side								9020367	9020369
1SD 310-50/0,75	druckseitig / pressure side	36	1 1/4"	176	80	19	96	160	auf Anfrage/ on request	auf Anfrage/ on request
	saugseitig / vacuum side								9026429	auf Anfrage/ on request
1SD 310-50/1,10	druckseitig / pressure side	36	1 1/4"	176	80	19	96	160	9020370	9020372
	saugseitig / vacuum side								9020371	9020373
1SD 410-50/0,75	druckseitig / pressure side	38	1 1/2"	220	120	19	100	163	9025681	auf Anfrage/ on request
	saugseitig / vacuum side								auf Anfrage/ on request	auf Anfrage/ on request
1SD 410-50/0,75 	druckseitig / pressure side	38	1 1/2"	220	120	19	100	163	9025681	auf Anfrage/ on request
	saugseitig / vacuum side								auf Anfrage/ on request	auf Anfrage/ on request
1SD 410-50/1,10	druckseitig / pressure side	38	1 1/2"	220	120	19	100	163	9020374	9020376
	saugseitig / vacuum side								2007647	9020377
1SE 410-50/1,10	druckseitig / pressure side	38	1 1/2"	220	120	19	100	163	9020374	9020376
	saugseitig / vacuum side								auf Anfrage/ on request	9020377
1SD 410-50/1,10 	druckseitig / pressure side	38	1 1/2"	220	120	19	100	163	9020374	9020376
	saugseitig / vacuum side								auf Anfrage/ on request	9020377
1SD 510-50/1,10	druckseitig / pressure side	53	2"	134	30	24	104	170	9024142	auf Anfrage/ on request
	saugseitig / vacuum side								9025115	auf Anfrage/ on request
1SD 510-50/1,10 	druckseitig / pressure side	auf Anfrage/ on request								
1SD 510-50/1,50 	druckseitig / pressure side	53	2"	264	24	24	104	160	9024888	auf Anfrage/ on request
	saugseitig / vacuum side								auf Anfrage/ on request	auf Anfrage/ on request
1SD 510-50/1,60	druckseitig / pressure side	53	2"	264	160	24	104	170	9024888	auf Anfrage/ on request
	saugseitig / vacuum side								9023480	auf Anfrage/ on request
1SD 510-50/2,20	druckseitig / pressure side	53	2"	264	160	24	104	170	9020378	9020380
	saugseitig / vacuum side								9020379	9020381
1SD 510-50/2,20 	druckseitig / pressure side	53	2"	264	160	24	104	170	auf Anfrage/ on request	auf Anfrage/ on request
	saugseitig / vacuum side								auf Anfrage/ on request	auf Anfrage/ on request

ZUBEHÖR 1SD/2SD ACCESSORIES 1SD/2SD



Typ Type	Betrieb/ Operation	d	d1	l	l1	l2	l3	h	Artikel-Nr. Article No.	Artikel-Nr. Article No.
									50 Hz	60 Hz
1SD 710-50/2,20	druckseitig / pressure side	53	2"	264	160	24	104	170	9026407	auf Anfrage/ on request
	saugseitig / vacuum side								9025116	auf Anfrage/ on request
1SD 710-50/2,20 IE3	druckseitig / pressure side	53	2"	264	160	24	104	170	9026407	auf Anfrage/ on request
	saugseitig / vacuum side								9025116	auf Anfrage/ on request
1SD 710-50/3,00	druckseitig / pressure side	53	2"	264	160	24	104	170	9020490	9025609
	saugseitig / vacuum side								9019920	auf Anfrage/ on request
1SD 710-50/3,00 IE3	druckseitig / pressure side	53	2"	264	160	24	104	170	9020490	auf Anfrage/ on request
	saugseitig / vacuum side								9019920	auf Anfrage/ on request
1SD 710-50/4,00	druckseitig / pressure side	53	2"	264	160	24	104	170	9020382	9020384
	saugseitig / vacuum side								9020383	9020385
1SD 710-50/4,00 IE3	druckseitig / pressure side	53	2"	264	160	24	104	170	9020382	auf Anfrage/ on request
	saugseitig / vacuum side								9020383	9020385
1SD 810-50/4,00	druckseitig / pressure side	69	2 1/2"	156	40	27	116	172	9025179	auf Anfrage/ on request
	saugseitig / vacuum side								9026449	auf Anfrage/ on request
1SD 810-50/4,00 IE3	druckseitig / pressure side	69	2 1/2"	156	40	27	116	172	auf Anfrage/ on request	auf Anfrage/ on request
	saugseitig / vacuum side								9026449	auf Anfrage/ on request
1SD 810-50/5,50	druckseitig / pressure side	69	2 1/2"	330	220	27	110	177	9023872	auf Anfrage/ on request
	saugseitig / vacuum side								9022727	auf Anfrage/ on request
1SD 810-50/5,50 IE3	druckseitig / pressure side	69	2 1/2"	330	220	27	110	177	9023872	auf Anfrage/ on request
	saugseitig / vacuum side								9022727	auf Anfrage/ on request
1SD 810-50/7,50	druckseitig / pressure side	69	2 1/2"	330	220	27	110	177	9020386	9020388
	saugseitig / vacuum side								9020387	9020389
1SD 810-50/7,50 IE3	druckseitig / pressure side	69	2 1/2"	330	220	27	110	177	9020386	9020388
	saugseitig / vacuum side								9020387	9020389
1SD 910-50/7,50 IE3	druckseitig / pressure side								auf Anfrage/ on request	
	saugseitig / vacuum side									
1SD 910-50/8,50	druckseitig / pressure side								auf Anfrage/ on request	
	saugseitig / vacuum side									
1SD 910-50/11,00 IE3	druckseitig / pressure side	105	4"	208	40	36	168	202	9022996	9022998
	saugseitig / vacuum side								9022997	9022999



ZUBEHÖR 1SD/2SD ACCESSORIES 1SD/2SD

Typ Type	Betrieb/ Operation	d	d1	l	l1	l2	l3	h	Artikel-Nr. Article No.	Artikel-Nr. Article No.
									50 Hz	60 Hz
1SD 910-50/12,50	druckseitig / pressure side	105	4"	208	40	36	168	202	9022996	9022998
	saugseitig / vacuum side								9022997	9022999
1SD 910-50/18,50	druckseitig / pressure side	105	4"	208	40	36	168	202	9022990	9022994
	saugseitig / vacuum side								9022993	9022995
1SD 910-50/18,50 	druckseitig / pressure side	105	4"	208	40	36	168	202	9022990	9022994
	saugseitig / vacuum side								9022993	9022995

Rohrgewinde nach DIN ISO 228 oder EN 10226 / Pipe thread according to DIN ISO 228 or EN 10226

Begrenzungsventil 2SD Relief valve 2SD

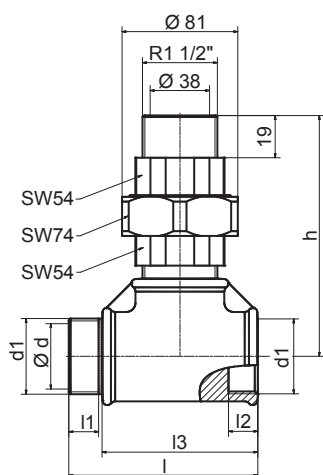

Typ Type	Betrieb/ Operation	d	d1	l	l1	l2	l3	h	Artikel-Nr. Article No.	Artikel-Nr. Article No.
									50 Hz	60 Hz
2SD 220-50/0,55	druckseitig / pressure side	36	1 1/4"	116	20	19	96	160	9019086	9019360
	saugseitig / vacuum side								9019087	9019361
2SD 320-50/1,10	druckseitig / pressure side	36	1 1/4"	116	20	19	96	160	9019326	9019362
	saugseitig / vacuum side								9019328	9019363
2SD 420-50/1,50 	druckseitig / pressure side	auf Anfrage/ on request								
2SD 420-50/1,60	druckseitig / pressure side	38	1 1/2"	120	20	19	100	163	9025106	auf Anfrage/ on request
	saugseitig / vacuum side								auf Anfrage/ on request	auf Anfrage/ on request
2SD 420-50/2,20	druckseitig / pressure side	38	1 1/2"	120	20	19	100	163	9019088	9019364
	saugseitig / vacuum side								9019089	9019365
2SD 420-50/2,20 	druckseitig / pressure side	38	1 1/2"	120	20	19	100	163	9019088	auf Anfrage/ on request
	saugseitig / vacuum side								9019089	auf Anfrage/ on request
2SD 520-50/3,00	druckseitig / pressure side	53	2"	134	30	24	104	170	9019090	9019366
	saugseitig / vacuum side								9019091	9019367
2SD 520-50/3,00 	druckseitig / pressure side	53	2"	134	30	24	104	170	auf Anfrage/ on request	auf Anfrage/ on request
	saugseitig / vacuum side								auf Anfrage/ on request	auf Anfrage/ on request
2SD 520-50/4,00	druckseitig / pressure side	53	2"	134	30	24	104	170	9024908	auf Anfrage/ on request
	saugseitig / vacuum side								auf Anfrage/ on request	auf Anfrage/ on request
2SD 720-50/3,00	druckseitig / pressure side	auf Anfrage/ on request								
	saugseitig / vacuum side									

ZUBEHÖR 1SD/2SD ACCESSORIES 1SD/2SD



Typ Type	Betrieb/ Operation	d	d1	l	l1	l2	l3	h	Artikel-Nr. Article No.	Artikel-Nr. Article No.
									50 Hz	60 Hz
2SD 720-50/4,00	druckseitig / pressure side	53	2"	134	30	24	104	170	9023484	auf Anfrage/ on request
	saugseitig / vacuum side			264	160				9023664	auf Anfrage/ on request
2SD 720-50/4,00 	druckseitig / pressure side	53	2"	134	30	24	104	170	9023484	auf Anfrage/ on request
	saugseitig / vacuum side								auf Anfrage/ on request	auf Anfrage/ on request
2SD 720-50/5,50	druckseitig / pressure side	53	2"	134	30	24	104	170	9021206	2004555
	saugseitig / vacuum side								9019093	9021208
2SD 720-50/5,50 	druckseitig / pressure side	53	2"	134	30	24	104	170	9021206	auf Anfrage/ on request
	saugseitig / vacuum side								9019093	auf Anfrage/ on request
2SD 720-50/7,50	druckseitig / pressure side	53	2"	134	30	24	104	170	9019092	9019368
	saugseitig / vacuum side								9019093	9019369
2SD 720-50/7,50 	druckseitig / pressure side	53	2"	134	30	24	104	170	9021737	9019368
	saugseitig / vacuum side								9019093	9019369
2SD 820-50/7,50 	druckseitig / pressure side	auf Anfrage/ on request								
2SD 820-50/8,50	druckseitig / pressure side	69	2 1/2"	150	40	27	110	177	9023871	auf Anfrage/ on request
	saugseitig / vacuum side								9026958	auf Anfrage/ on request
2SD 820-50/11,00	druckseitig / pressure side	69	2 1/2"	150	40	27	110	177	9023582	9026143
	saugseitig / vacuum side								2006969	auf Anfrage/ on request
2SD 820-50/11,00 	druckseitig / pressure side	69	2 1/2"	150	40	27	110	177	9023582	auf Anfrage/ on request
	saugseitig / vacuum side								2006969	auf Anfrage/ on request
2SD 820-50/15,00	druckseitig / pressure side	69	2 1/2"	150	40	27	110	177	9019094	9019370
	saugseitig / vacuum side								9019095	9019371
2SD 820-50/15,00 	druckseitig / pressure side	69	2 1/2"	150	40	27	110	177	auf Anfrage/ on request	auf Anfrage/ on request
	saugseitig / vacuum side								9019095	auf Anfrage/ on request

Rohrgewinde nach DIN ISO 228 oder EN 10226 / Pipe thread according to DIN ISO 228 or EN 10226



ZUBEHÖR 1SD/2SD ACCESSORIES 1SD/2SD

Begrenzungsventil 2SD 920

Relief valve 2SD 920

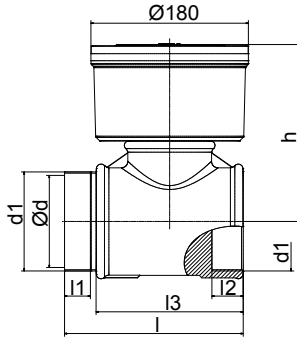

Typ Type	Betrieb/ Operation	d	d1	l	l1	l2	l3	h	Artikel-Nr. Article No.	
									50 Hz	60 Hz
2SD 920-50/11,00 (IE3)	druckseitig / pressure side saugseitig / vacuum side								auf Anfrage/ on request	
2SD 920-50/12,50	druckseitig / pressure side saugseitig / vacuum side								auf Anfrage/ on request	
2SD 920-50/15,00 (IE3)	druckseitig / pressure side saugseitig / vacuum side	105	4"	203	29	36	168	202	9023008 9023009	9023010 auf Anfrage/ on request
2SD 920-50/16,50	druckseitig / pressure side saugseitig / vacuum side	105	4"	203	29	36	168	202	9023008 9023009	9023010 9023011
2SD 920-50/18,50 (IE3)	druckseitig / pressure side saugseitig / vacuum side	105	4"	203	29	36	168	202	9023004 9023005	9023006 9023007
2SD 920-50/20,00	druckseitig / pressure side saugseitig / vacuum side	105	4"	203	29	36	168	202	9023004 9023005	9023006 9023007
2SD 920-50/25,00	druckseitig / pressure side saugseitig / vacuum side	105	4"	203 393	29	36	168	202	9023000 9023001	9023002 9023003

Rohrgewinde nach DIN ISO 228 oder EN 10226 / Pipe thread according to DIN ISO 228 or EN 10226

ZUBEHÖR 1SD/2SD ACCESSORIES 1SD/2SD



Feinfilter Fine filter

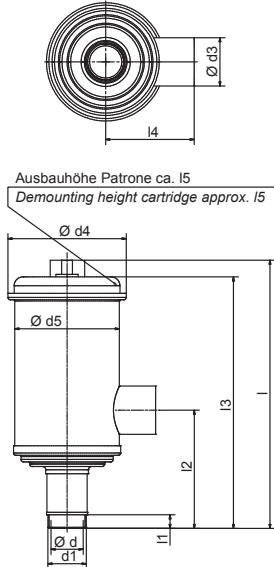

Typ Type	d	d1	d3	d4	d5	l	l1	l2	l3	l4	l5	Artikel-Nr. Article No.
1SD 210 1SE 210 2SD 220	31	1 1/4"	60	147	130	380	19	195	360	110	235	9018918
1SD 310 2SD 320	31	1 1/4"	60	147	130	380	19	195	360	110	235	9018918
1SD 410 1SE 410 2SD 420	40	1 1/2"	60	147	130	400	15	215	380	110	235	9019069
1SD 710 2SD 520 2SD 720	50	2"	60	167	150	480	15	230	460	110	300	9019070
												3,0 - 6,0 kW 4,0 - 4,6 kW ^(IE3)
1SD 510 2SD 720	50	2"	60	167	150	400	15	150	380	110	300	9012430
												5,5 - 9,8 kW 5,5 - 8,6 kW ^(IE3)
1SD 810 2SD 820	68	2 1/2"	100	208	190	455	20	170	440	155	360	9012429

Rohrgewinde nach DIN ISO 228 oder EN 10226 / Pipe thread according to DIN ISO 228 or EN 10226
Allgemeintoleranzen: DIN EN ISO 13920 BF / General tolerances: DIN EN ISO 13920 BF

Feinfilter Fine filter

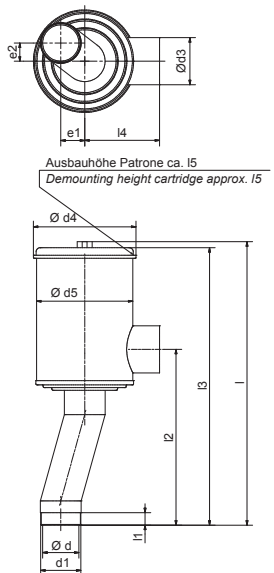

Typ Type	d	d1	d3	d4	d5	l	l1	l2	l3	l4	l5	e1	e2	Artikel-Nr. Article No.
1SD 910 2SD 920	100	4"	132	287	270	795	35	493	778	210	400	67	51	9023226

Rohrgewinde nach DIN ISO 228 oder EN 10226 / Pipe thread according to DIN ISO 228 or EN 10226
Allgemeintoleranzen: DIN EN ISO 13920 BF / General tolerances: DIN EN ISO 13920 BF

Einbaubeispiel Installation example

Nur für 2SD 720 - 5,5 bis 9,8 kW
Only for 2SD 720 - 5.5 to 9.8 kW

Standard
Standard

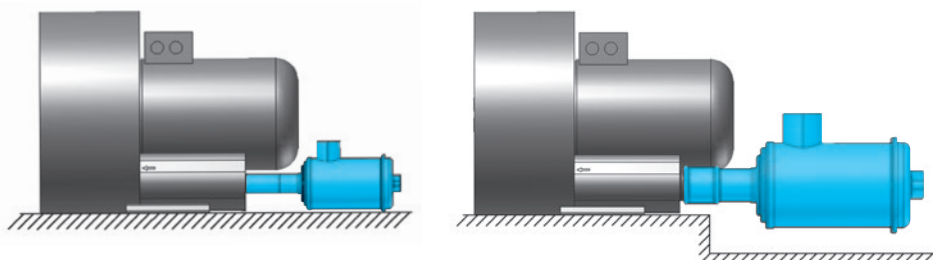



ZUBEHÖR 1SD/2SD ACCESSORIES 1SD/2SD

Feinfilter mit Rohrbogen Fine filter with pipe bend

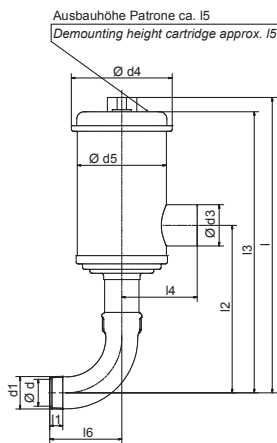

Typ Type	d	d1	d3	d4	d5	l	l1	l2	l3	l4	l5	l6	Artikel-Nr. Article No.
1SD 210 1SE 210 2SD 220	31	1 1/4"	60	147	130	430	19	245	410	110	235	155	9019071
1SD 310 2SD 320	31	1 1/4"	60	147	130	430	19	245	410	110	235	155	9019071
1SD 410 1SE 410 2SD 420	40	1 1/2"	60	147	130	430	15	245	410	110	235	170	9019072
1SD 510	50	2"	60	167	150	485	15	235	465	110	300	180	9020279
2SD 520	50	2"	60	167	150	485	15	235	465	110	300	310	9019073
1SD 710 2SD 720 3,0 - 6,0 kW 4,0 - 4,6 kW (IE3)	50	2"	60	167	150	485	15	235	465	110	300	310	9019073
2SD 720 5,5 - 9,8 kW 5,5 - 8,6 kW (IE3)	50	2"	60	167	150	485	15	235	465	110	300	102	9019074
1SD 810 2SD 820 8,5 - 9,8 kW 7,5 - 8,6 kW (IE3)	68	2 1/2"	100	208	190	570	20	285	555	155	360	210	9023067
2SD 820 11,0 - 21,3 kW 11,0 - 17,3 kW (IE3)	68	2 1/2"	100	208	190	570	20	285	555	155	360	115	9019075

Rohrgewinde nach DIN ISO 228 oder EN 10226 / Pipe thread according to DIN ISO 228 or EN 10226

Allgemeintoleranzen: DIN EN ISO 13920 BF / General tolerances: DIN EN ISO 13920 BF

Feinfilter mit Rohrbogen Fine filter with pipe bend

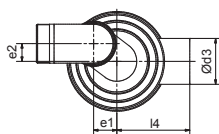

Ausbauhöhe Patrone ca. 15
Demounting height cartridge approx. 15

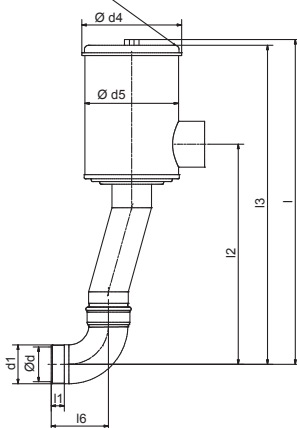

Typ Type	d	d1	d3	d4	d5	l	l1	l2	l3	l4	l5	l6	e1	e2	Artikel-Nr. Article No.
1SD 810 2SD 820 8,5 - 9,8 kW	100	4"	132	287	270	936	35	634	919	210	400	165	67	51	9023670
1SD 910 2SD 920	100	4"	132	287	270	936	35	634	919	210	400	165	67	51	9023670

Rohrgewinde nach DIN ISO 228 oder EN 10226 / Pipe thread according to DIN ISO 228 or EN 10226

Allgemeintoleranzen: DIN EN ISO 13920 BF / General tolerances: DIN EN ISO 13920 BF

Ersatzpatronen zu Feinfilter / Replacement cartridge for fine filter

Typ Type	Artikel-Nr. Article No.
1SD 210 - 2SD 420	9011999
1SD 510 - 2SD 720	9012004
1SD 810 - 2SD 820 11,0 - 21,3 kW	9012003
2SD 820 8,5 - 9,8 kW - 2SD 920	9011998

ZUBEHÖR 1SD/2SD ACCESSORIES 1SD/2SD



Metallfilter Metal filter

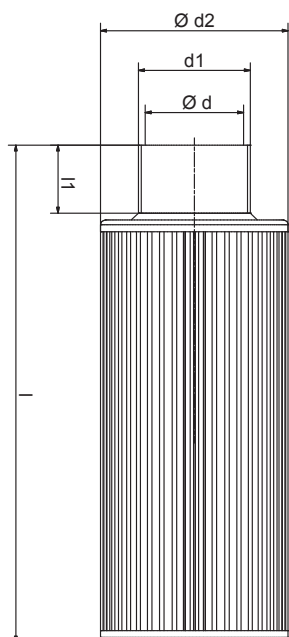

Typ Type	d	d1	d2	l	l1	Artikel-Nr. Article No.
1SD 210 1SE 210 2SD 220	31	1 1/4"	80	245	19	9018917
1SD 310 2SD 320	31	1 1/4"	80	245	19	9018917
1SD 410 1SE 410 2SD 420	42	1 1/2"	80	265	25	9019062
1SD 510 2SD 520	54	2"	119	315	25	9019063
1SD 710 1SD 810 2SD 720 3,0 - 6,0 kW 4,0 - 4,6 kW IE3	54	2"	119	315	25	9020364
2SD 720 5,5 - 9,8 kW 5,5 - 8,6 kW IE3	54	2"	119	283	25	9015960
1SD 810 2SD 820 8,5 - 9,8 kW 7,5 - 8,6 kW IE3	69	2 1/2"	140	430	25	9023064
2SD 820 11,0 - 21,3 kW 11,0 - 17,3 kW IE3	54	2 1/2"	140	336	25	9015644
2SD 840						
1SD 910 2SD 920	105	4"	209	390	35	9023166

Rohrgewinde nach DIN ISO 228 oder EN 10226 / Pipe thread according to DIN ISO 228 or EN 10226

Einbaubeispiel Installation example

Standard
Standard

Nur für:
2SD 520
2SD 720 - 3,0 bis 6,0 kW
2SD 820 - 8,5 bis 9,8 kW

Only for:
2SD 520
2SD 720 - 3,0 to 6.0 kW
2SD 820 - 8,5 to 9.8 kW

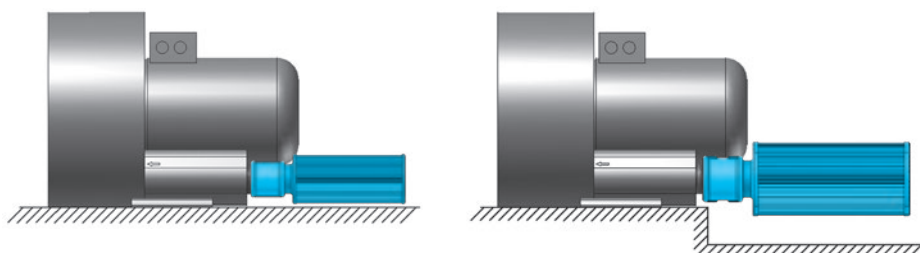



ZUBEHÖR 1SD/2SD ACCESSORIES 1SD/2SD

Metallfilter mit Rohrbogen

Metal filter with pipe bend

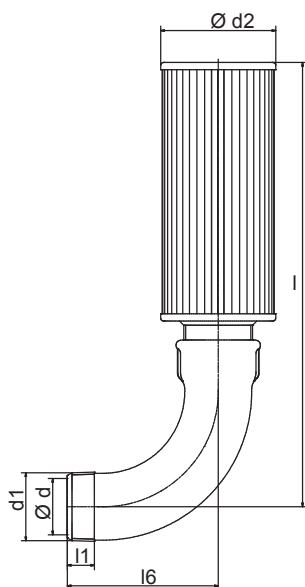

Typ Type	d	d1	d2	l	l1	l6	Artikel-Nr. Article No.
1SD 210 1SE 210 2SD 220	31	1 1/4"	80	290	19	155	9019066
1SD 310 2SD 320	31	1 1/4"	80	290	19	155	9019066
1SD 410 1SE 410 2SD 420	42	1 1/2"	80	210	25	170	9019064
1SD 510 2SD 520	54	2"	119	380	25	180	9019065
1SD 710 2SD 720 3,0 - 6,0 kW 4,0 - 4,6 kW (IE3) 2SD 740 4,0 - 6,0 kW	54	2"	119	380	25	310	9020365
2SD 720 5,5 - 9,8 kW 5,5 - 8,6 kW (IE3) 2SD 740 5,5 - 6,8 kW	54	2"	119	380	25	102	9019067
1SD 810 2SD 820 8,5 - 9,8 kW 7,5 - 8,6 kW (IE3)	69	2 1/2"	140	445	25	210	9023065
2SD 820 11,0 - 21,3 kW 11,0 - 17,3 kW (IE3) 2SD 840 8,5 - 17,3 kW 7,5 - 12,6 kW (IE3)	69	2 1/2"	140	445	25	115	9019068
1SD 910 2SD 920	105	4"	209	530	35	165	9023668

Rohrgewinde nach DIN ISO 228 oder EN 10226 / Pipe thread according to DIN ISO 228 or EN 10226

Rohrschalldämpfer Tube silencer

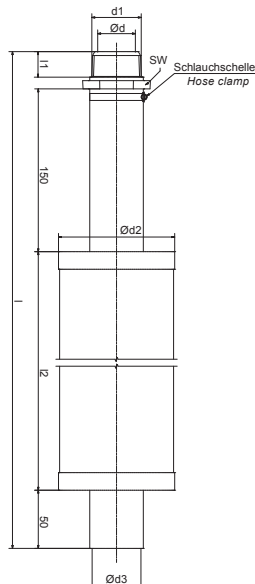

Typ Type	d	d1	d2	d3	SW	l	l1	l2	Artikel-Nr. Article No.
1SD 210 1SE 210 2SD 220	30	1 1/4"	90	45	50	640	19	400	9019082
1SD 310 2SD 320	30	1 1/4"	90	45	50	640	19	400	9019082
1SD 410 1SE 410 2SD 420	38	1 1/2"	105	50	55	650	19	400	9019083
1SD 510 2SD 520	50	2"	112	60	70	660	24	400	9019084
1SD 710 2SD 720 2SD 740	50	2"	112	60	70	660	24	400	9019084
1SD 810 2SD 820 2SD 840	60	2 1/2"	120	80	85	660	27	400	9019085
1SD 910 2SD 920	104	4"	112	112	-	1230	15	1000	9023159

Rohrgewinde nach DIN ISO 228 oder EN 10226 / Pipe thread according to DIN ISO 228 or EN 10226

Maße in mm - unverbindlich. Änderungen vorbehalten.
Dimensions in mm - without obligation. Subject to modification.

ZUBEHÖR 1SD/2SD ACCESSORIES 1SD/2SD



Kugelhahn für druckseitigen Anbau

Ball valve for pressure side mounting

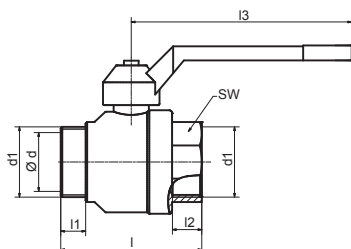

Typ Type	d	d1	l	l1	l2	l3	h	SW	Artikel-Nr. Article No.
1SD 210 1SE 210 2SD 220	32	1 1/4"	85	16	18	120	70	48	9018753
1SD 310 2SD 320	32	1 1/4"	85	16	18	120	70	48	9018753
1SD 410 1SE 410 2SD 420	40	1 1/2"	96	17	20	150	80	54	9013287
1SD 510 2SD 520	49	2"	307	20	21	150	87	67	9020392
1SD 710 2SD 720 3,0 - 6,0 kW 4,0 - 4,6 kW	49	2"	307	20	21	150	87	67	9020392
2SD 720 5,5 - 9,8 kW 5,5 - 8,6 kW	49	2"	110	20	21	15	87	67	9013288
1SD 810 2SD 820 2SD 840	64	2 1/2"	173	27	21	200	120	85	9018921
1SD 910 2SD 920	105	4"	220	30	30	240	145	127	9018925

Rohrgewinde nach DIN ISO 228 oder EN 10226 / Pipe thread according to DIN ISO 228 or EN 10226

Anschlussstutzen Connection pipe

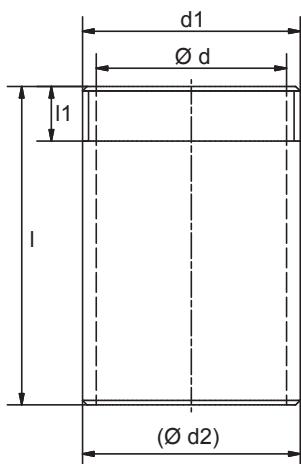

Typ Type	d	d1	d2	l	l1	Artikel-Nr. Article No.
1SD 210 1SE 210 2SD 220	36	G1 1/4"	42,4	70	12	9018757
1SD 310 2SD 320	36	G1 1/4"	42,4	70	12	9018757
1SD 410 1SE 410 2SD 420	42	G1 1/2"	48,3	70	12	9012415
1SD 510 2SD 520	53	G2"	60,3	70	12	9012416
1SD 710 2SD 720 2SD 740	53	G2"	60,3	70	12	9012416
1SD 810 2SD 820 2SD 840	69	G2 1/2"	76,1	70	15	9012417
1SD 910 2SD 920	104	G4"	110	70	15	9018756

Rohrgewinde nach DIN ISO 228 / Pipe thread according to DIN ISO 228

Gewinderohr nach EN10255-M / Screwed tube according to EN 10255-M



ZUBEHÖR ANSCHLUSS-SYSTEMKOMPONENTEN ACCESSORIES SYSTEM COMPONENTS



Air Knife	Air Knife
<ul style="list-style-type: none"> ■ Zum Trocknen, Kühlen, Reinigen, Aus- und Abblasen als ideales Anschlusszubehör für Ventilatoren geeignet ■ Sorgt für einen gleichmäßigen Luftstrom oder Luftvorhang und lenkt diesen gezielt und perfekt an die gewünschte Stelle ■ Schlitzbreite einstellbar von 1 mm bis 10 mm ■ Werkstoff: Niro 	<ul style="list-style-type: none"> ■ <i>Ideally suitable as a blower connection accessory for drying, cooling, cleaning, blowing out and de-dusting</i> ■ <i>Provides a consistent air flow or air curtain and directs it precisely and perfectly at the desired spot</i> ■ <i>Slot width adjustable between 1 mm and 10 mm</i> ■ <i>Material: stainless steel</i>

Für detaillierte Informationen zu unseren Anschluss-Systemkomponenten wenden Sie sich bitte an unser [Produktmanagement](mailto:support@elektor.de) (support@elektor.de).

For detailed information about the system components of our connection system, please contact our [Product Management](mailto:support@elektor.com) (support@elektor.com).

**FÜR IHRE NOTIZEN
FOR YOUR NOTES**

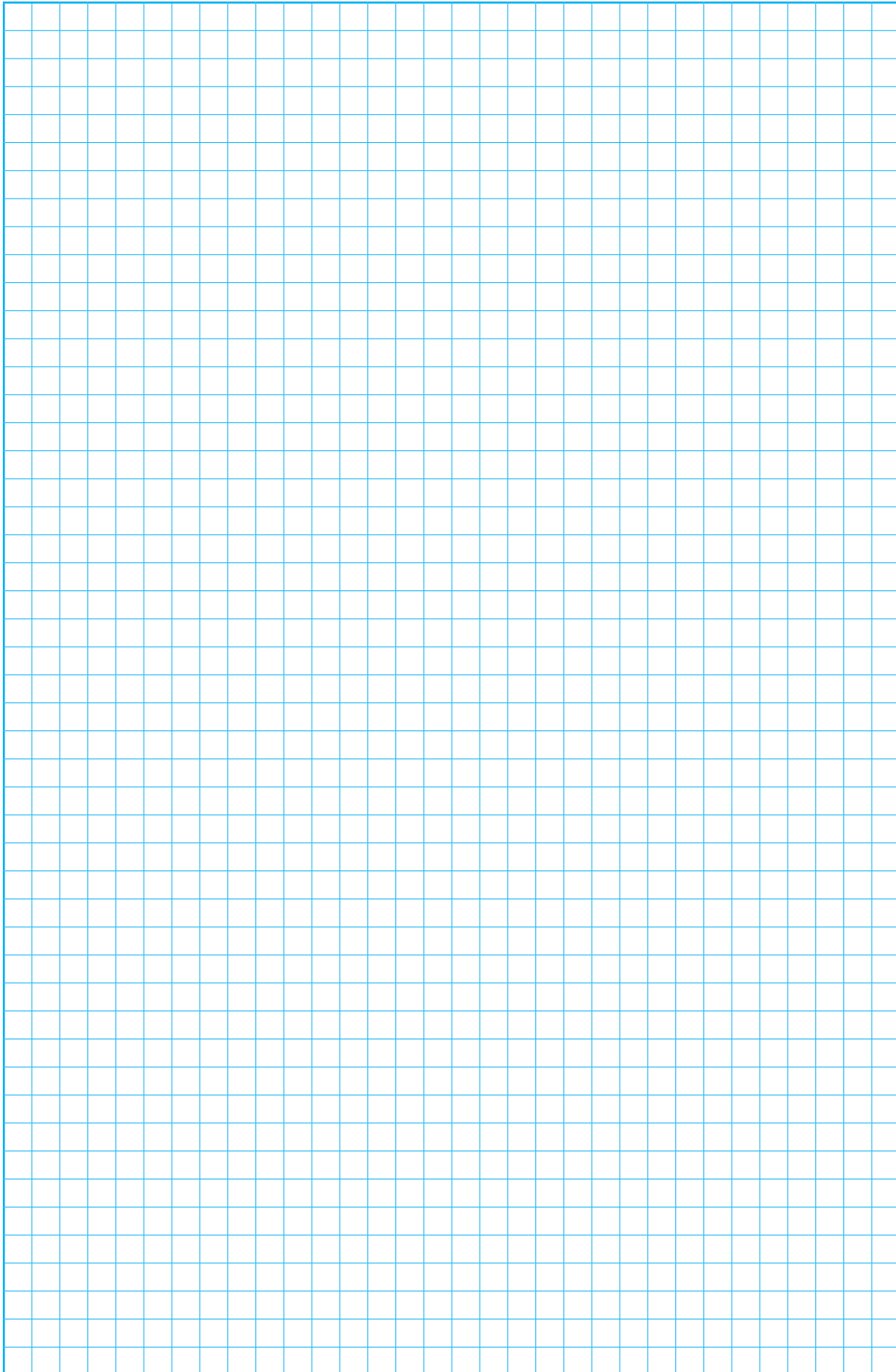

Elektorr

airsystems gmbh

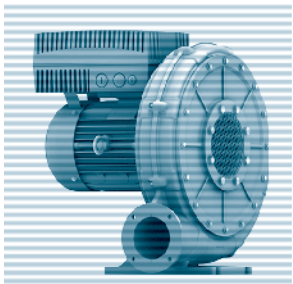
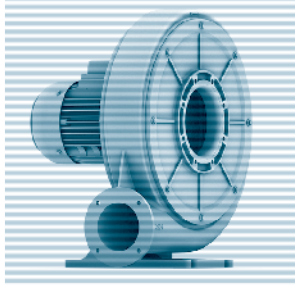
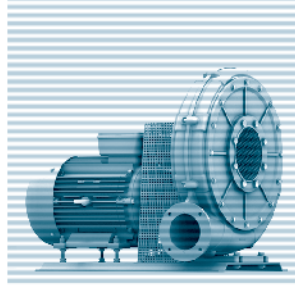
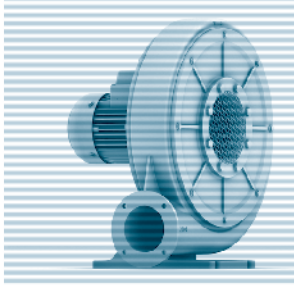
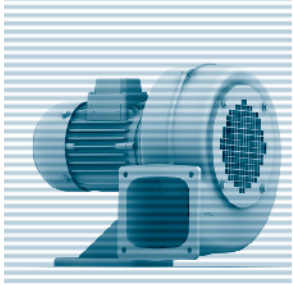

PRODUKT-ÜBERSICHT
PRODUCT RANGE

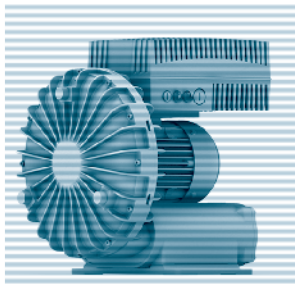
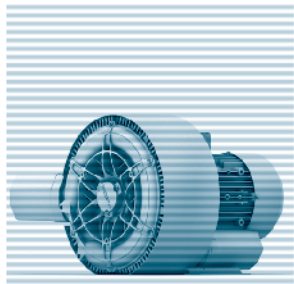
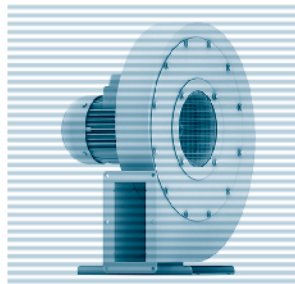

Niederdruck-ventilatoren
Low pressure blowers
ND

Mitteldruck-ventilatoren
Medium pressure blowers
RD

ATEX-Niederdruckventilatoren
ATEX Low pressure blowers
ND ATEX

ATEX-Mitteldruckventilatoren
ATEX Medium pressure blowers
RD ATEX

Seitenkanal-verdichter
Side channel blowers
SD

Hochdruck-ventilatoren
High pressure blowers
HRD

Förder-ventilatoren
Conveying blowers
RD F

ATEX-Hochdruckventilatoren
ATEX High pressure blowers
HRD ATEX

Hellmuth-Hirth-Straße 2
73760 Ostfildern
Tel. +49 711 31973-0
Fax +49 711 31973-5000
info@elektorr.de
www.elektorr.de